



SERVICE MANUAL

**S1050**



# CONTENTS

---

## I . SPECIFICATION

1. CAMERA SPECIFICATION .....	4
2. SYSTEM REQUIREMENTS .....	7
3. TFT LCD PANEL MARK .....	8
4. CONNECTION DIAGRAM .....	11
5. IDENTIFICATION OF FEATURES .....	12

## II . EXPLODED VIEW AND PARTS LIST

1. MAIN ASSEMBLY .....	14
2. BODY ASSEMBLY .....	16
3. BARREL ASSEMBLY .....	18
4. BARRIER ASSEMBLY .....	22
5. STROBO ASSEMBLY.....	24
6. FRONT COVER ASSEMBLY.....	26
7. REAR COVER ASSEMBLY .....	28
8. PACKING ITEM .....	30

## III . ADJUSTMENT

1. FIRMWARE .....	34
2. ADJUSTMENT .....	48

## IV . PATTERN DIAGRAM

1. PARTS ARRANGEMENT FOR EACH PCB ASS' Y	
1) MAIN_TOP .....	116
2) MAIN_BOTTOM .....	117
3) MAIN_CCD .....	118
4) MAIN_MODE .....	119
5) STROBO .....	120

---

## V. CIRCUIT DIAGRAM

1) MAIN .....	121
2) MAIN_DDR .....	122
3) 3) MAIN_CCD(FEP) .....	123
4) MAIN_I/O LCD .....	124
5) MAIN_KEY .....	125
6) MAIN_LENS(MOTOR) .....	126
7) MAIN_POWER .....	127
8) MAIN_STROBO .....	128
9) CCD .....	129
10) MODE .....	130
11) STROBO .....	131

<b>VI. SERVICE INFORMATION .....</b>	<b>132</b>
--------------------------------------	------------

# I . SPECIFICATION

## 1. CAMERA SPECIFICATION

**Image Sensor** - Type : 1/1.8" CCD  
- Effective Pixel : Approx.10.1 Mega-pixel  
- Total Pixel : Approx. 10.3 Mega-pixel

**Lens** - Focal Length : SHD Lens f = 7.8~39mm (35mm film equivalent : 38~190mm)  
- F No. : Wide : 2.8~7.4  
Tele : 4.5~11.7  
- Digital Zoom : · Still Image mode : 1.0X ~ 5.0X  
· Play mode : 1.0X ~ 14.3X (depends on image size)

**LCD Monitor** - 3.0" color TFT LCD (230,000 dots)

**Focusing** - Type : TTL auto focus (Multi AF, Center AF, Face Recognition AF)  
- Range

	Wide	Tele
Normal	80cm ~ Infinity	1.5m ~ Infinity
Macro	10cm ~ 80cm	50cm ~ 1.5m
Auto Macro	1cm~10cm (Wide Only)	
Super Macro	10cm ~ Infinity	50cm ~ Infinity
Manual Focus	1cm ~ Infinity	50cm ~ Infinity

**Shutter** - Shutter Speed : 1 ~ 1/2,000sec. (Manual : 16 ~ 1/2,000 sec.)

**Exposure** - Control : Program AE  
- Metering : Multi, Spot, Center weighted, Face Recognition  
- Compensation :  $\pm 2$ EV (1/3EV steps)  
- ISO Equivalent : Auto, 80, 100, 200, 400, 800, 1600

**Flash** - Modes : Auto, Auto & Red-eye reduction, Fill-in flash, Slow sync, Flash off  
- Range : Wide : 0.2m ~ 3.0m, Tele : 0.4m ~ 2.5m (ISO AUTO)  
- Recharging Time : Approx. 5 sec.

**Sharpness** - Soft+, Soft, Normal, Vivid, Vivid+

**Color Effect** - Normal, B&W, Sepia, Red, Green, Blue, Negative, User Set

**White Balance** - Auto, Daylight, Cloudy, Fluorescent\_H, Fluorescent\_L, Tungsten, Custom

**Voice Recording** - Voice Recording (max.10 hour)  
- Voice Memo in Still Image (max. 10 sec.)

**Date Imprinting** - Date, Date & Time, Off (user selectable)

**Shooting**







- Still Image :
  - Modes : Auto, Program, A, S, M, ASR, Scene
  - Scene : Night, Portrait, Children, Landscape, Close-up, Text, Sunset, Dawn, Backlight, Fireworks, Beach & Snow
  - Shooting : Single, Continuous, AEB, Wise Shot, Motion capture
  - Self-timer : 2 sec., 10 sec., Double (10 sec., 2 sec.)
- Movie Clip :
  - With Audio or without Audio (user selectable, recording time : memory capacity dependent)
    - ※ The maximum file size of continuous movie clip is 2GB.
  - Size : 800X592, 720X480, 640X480, 320X240
    - ※ 30 FPS cannot be used in 800x592 size.
  - Frame rate : 30 fps, 20fps, 15 fps
  - Optical zoom: Max. 5X
  - Movie Stabilizer
  - Movie Editing (Embedded): Pause during recording, Still Image Capture, Time Trimming

**Storage**

- Media :
  - Internal memory : Approx.48MB flash memory
  - External memory : SDHC / MMC / SD card (Up to 4GB Guaranteed)
- File Format :
  - Still Image : JPEG (DCF), EXIF 2.2, DPOF 1.1, PictBridge 1.0
  - Movie Clip : AVI (MJPEG)
  - Audio : WAV
- Image Size

						
3648x2736	3648x2432	3072x2304	3648x2052	2592x1944	2048x1536	1024x768

- Capacity (256 MB MMC)

						
48	53	67	67	95	142	459
94	104	128	128	183	269	744
109	151	197	197	269	363	868

- ※ These figures are measured under Samsung's standard conditions and may vary depending on shooting conditions and camera settings.

## I . SPECIFICATION

---

<b>"E" Button</b>	- Effect : Color, Image Adjust, Fun (Highlight, Composite, Photo Frame) - Editing : Resize, Rotate, Color, Special Color, Image Adjust (Red eye fix, Brightness, Contrast, Saturation, Add Noise), Fun (Cartoon, Highlight, Composite, Photo Frame, Sticker)
<b>Image Play</b>	- Single image, Thumbnails, Slide show, Movie Clip
<b>Interface</b>	- Digital output connector : USB 2.0 High Speed - Audio : Mono - Video output : NTSC, PAL (user selectable)
<b>Power Source</b>	- Primary Battery : 2 x AA Alkaline - Rechargeable battery (Optional) : SNB-2512B KIT (2 x AA 2500mAh Ni-MH Battery & Charger) ※ Included battery may vary depending on sales region.
<b>Dimensions (WxHxD)</b>	- 104.5 x 64.2 x 25.5mm (excluding protrusions)
<b>Weight</b>	- Approx. 205g (without batteries and card)
<b>Operating Temperature</b>	- 0 ~ 40° C
<b>Operating Humidity</b>	- 5 ~ 85%
<b>Software</b>	- Digimax Master, Adobe Reader

## 2. System Requirements

For Windows	For Macintosh
PC with processor better than Pentium II 450MHz (Pentium 700MHz recommended)	Power Mac G3 or later
Windows 98SE/2000/ME/XP/Vista	Mac OS 9.2 ~ 10.3
Minimum 64MB RAM 200MB of available hard disk space	Minimum 64MB RAM 110MB of available hard-disk space
USB port	USB port
CD-ROM drive	CD-ROM drive
1024x768 pixels, 16bit color display compatible monitor (24bit color display recommended) MicroSoft DirectX 9.0C	

### 3. LCD monitor indicator

- Recording mode

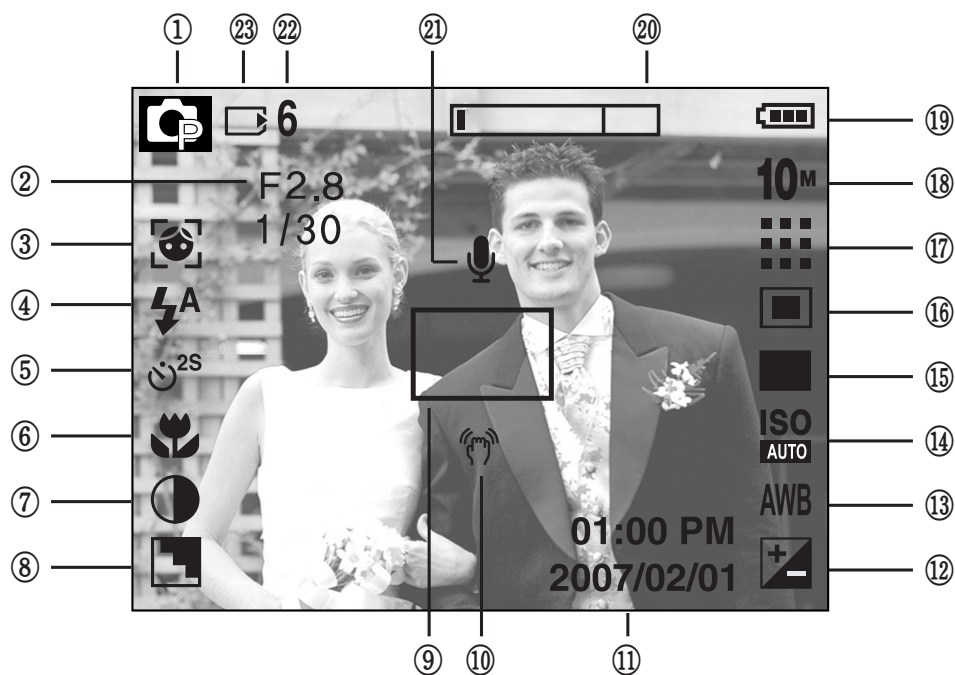

[Image & Full Status]



No.	Description	Icons
1	Recording mode	
2	Aperture Value/ Shutter Speed	F2.8, 1/30
3	Face Recognition	
4	Flash	
5	Self-timer	
6	Macro	
7	Contrast	
8	Sharpness	
9	Auto focus frame	
10	Camera shake warning	
11	Date/ Time	2007/02/01 01:00 PM
12	Exposure compensation	
13	White Balance	
14	ISO	
15	Continuous shot	
16	Metering	
17	Image quality	
18	Image size	
19	Battery	
20	Optical/ Digital Zoom bar/ Digital Zoom rate	
21	Voice memo/ Without Sound	
22	Number of available shots remaining	6
	Movie / Voice recording time	00:00:00
23	Card inserted indicator	

■ Play mode

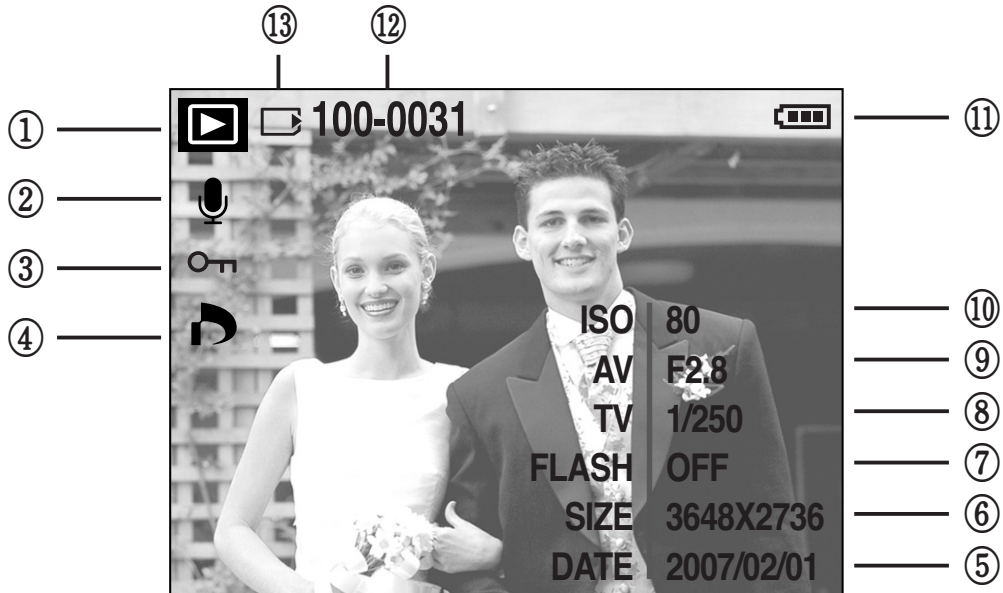

No.	Description	Icon
1	Play mode icon	
2	Voice Memo	
3	Protect	
4	DPOF	
5	Recording date	2007/02/01
6	Image size	3648X2736 ~ 256X192
7	Flash	ON/OFF
8	Shutter speed	16 ~ 1/2000
9	Aperture value	F2.8 ~ 11.7
10	ISO	80 ~ 1600
11	Battery	
12	Folder name & File name	100-0031
13	Memory card indicator	

#### 4. CONNECTION DIAGRAM

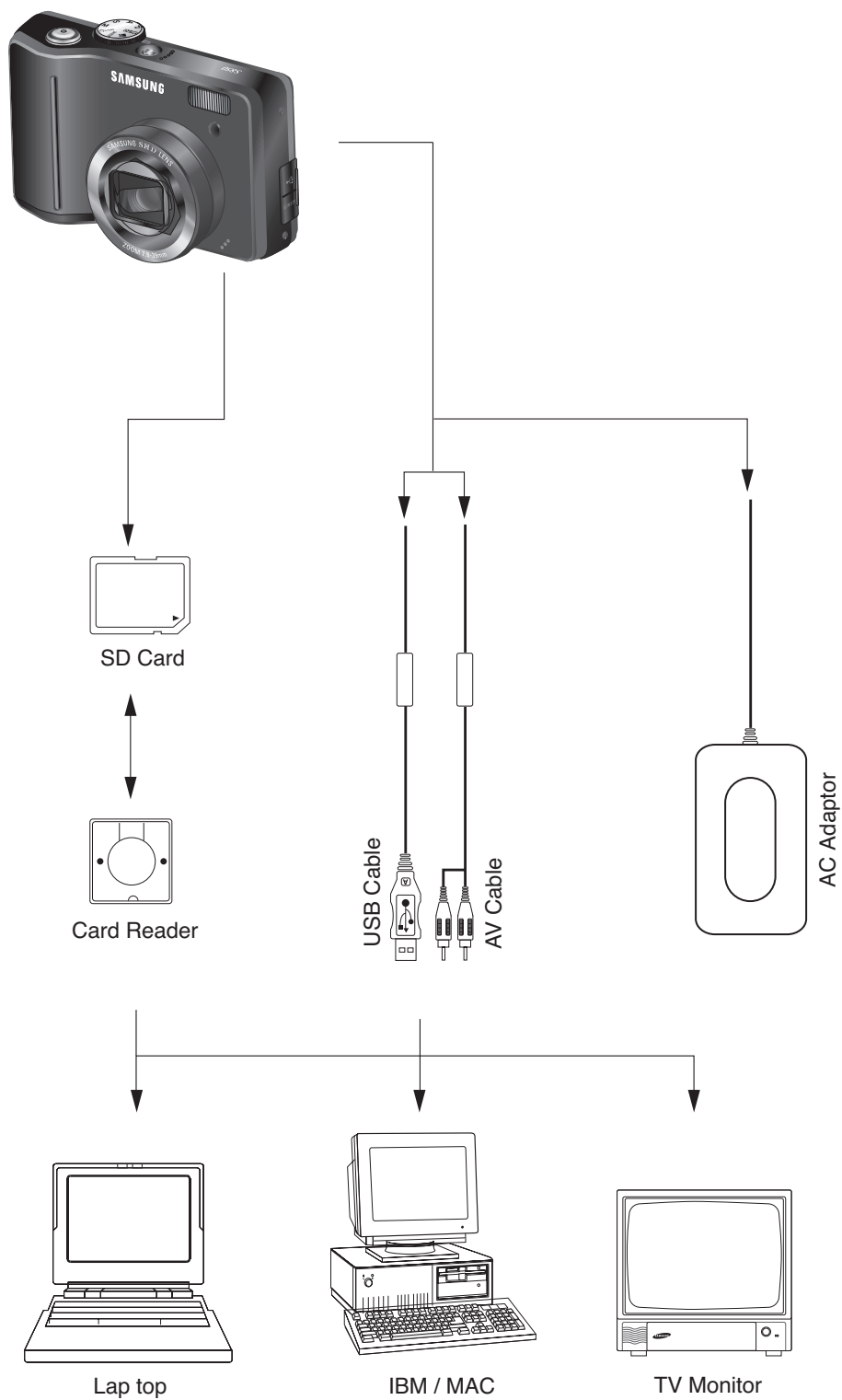

## 5. IDENTIFICATION OF FEATURES

### Front & Top



### Back & Bottom

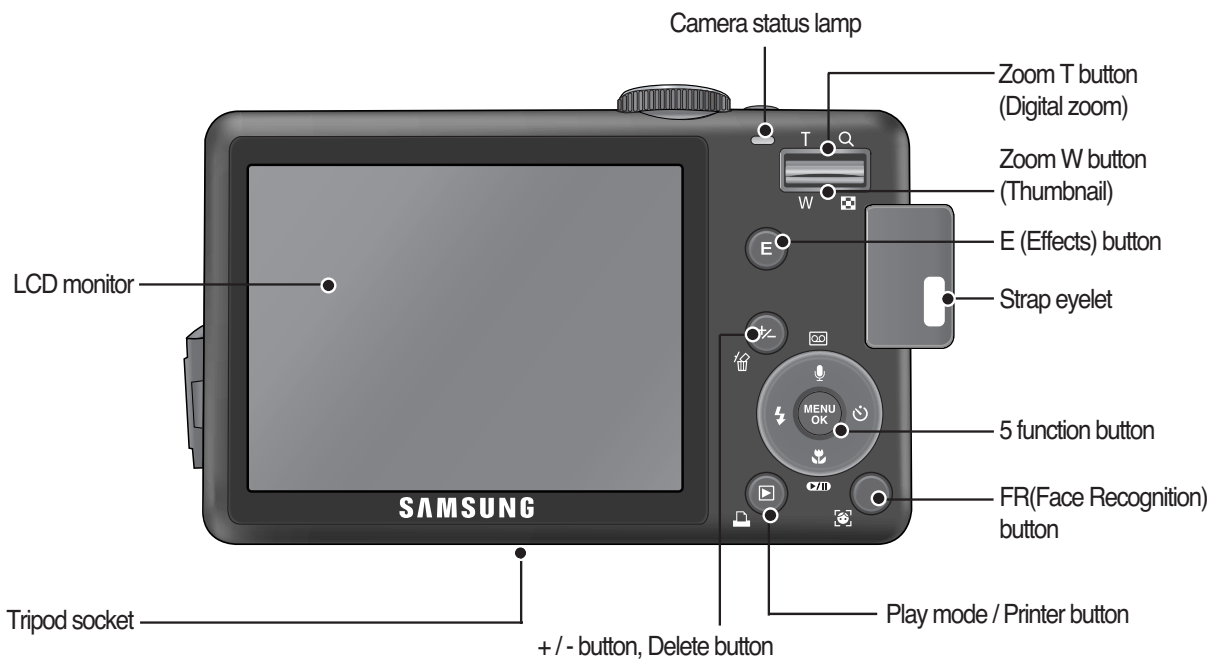

**Bottom**

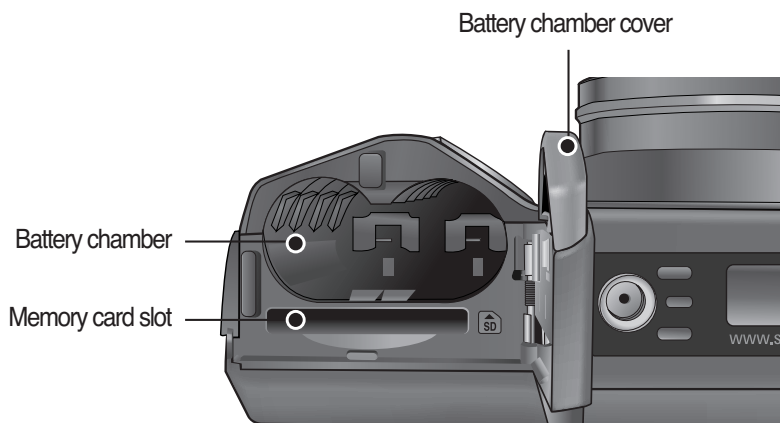

**5-function button**

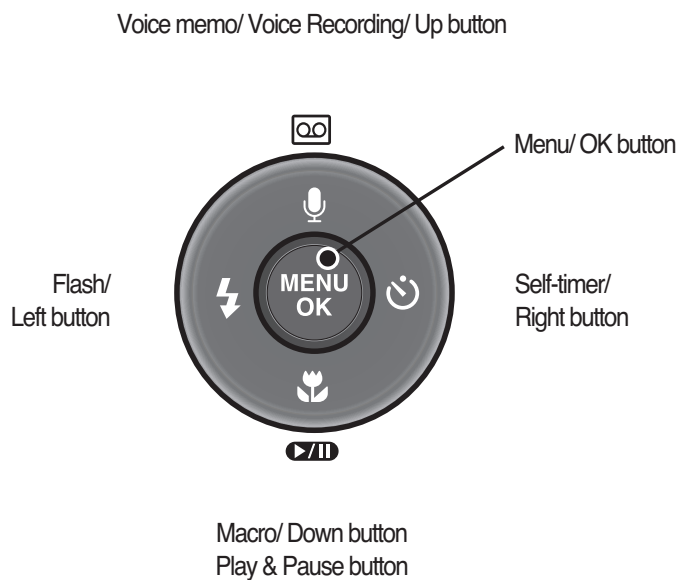

## II . EXPLODED VIEW AND PART LIST

### 1. MAIN ASSEMBLY

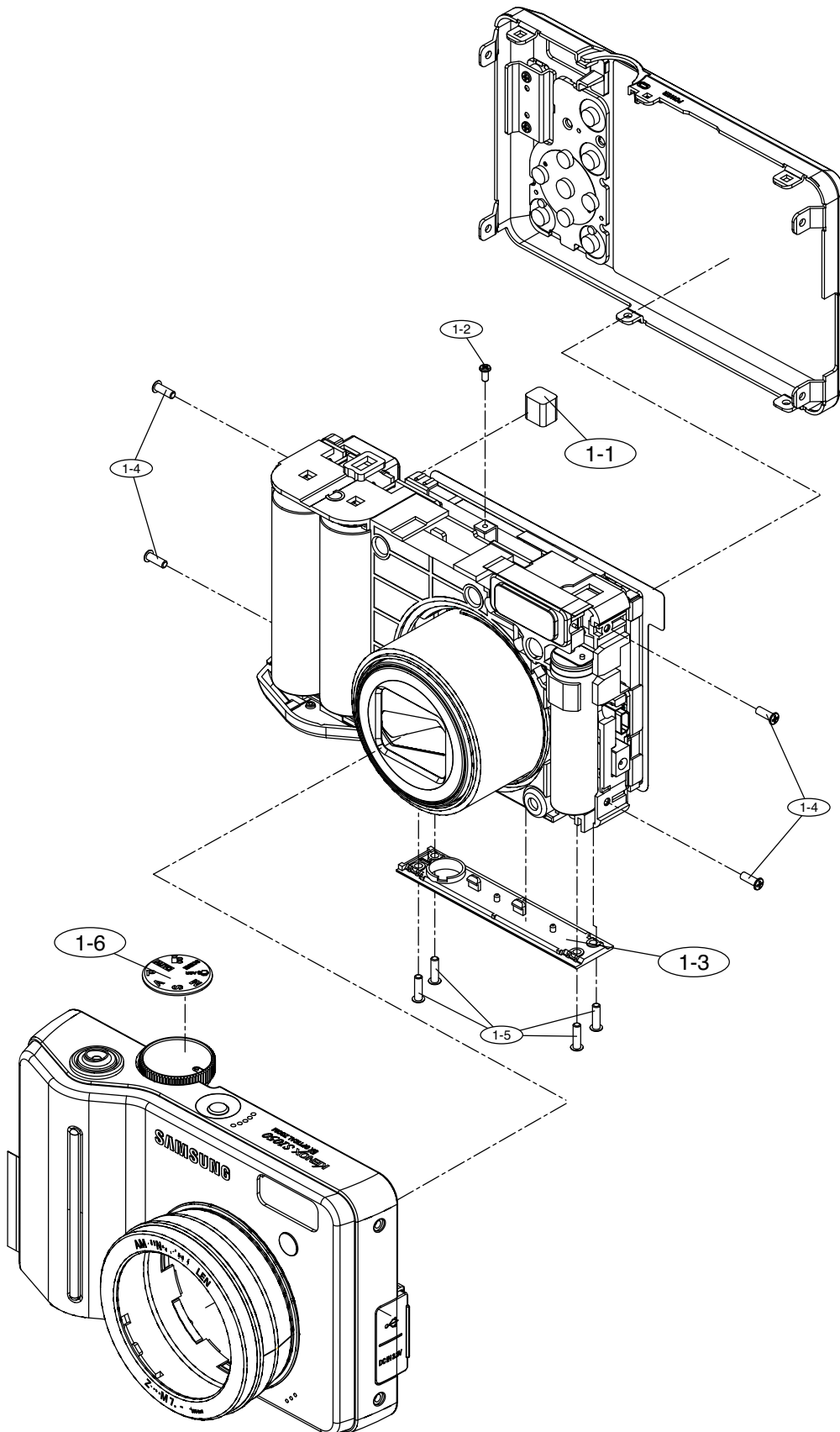

► PARTS LIST

Fig.No	Parts No.	Parts Name	Q'ty	Supply Available Parts	Remarks
1-1	Q7409279801A	PCB SHIELD FORM	1	O	
1-2	Q6001016501A	SCREW	1	X	
1-3	Q7217398301A	BOTTOM DECO	1	O	
1-4	Q6003002402A	SCREW	4	X	
1-5	Q6003002702A	SCREW	4	X	
1-6	Q7104002401A	MODE DIAL DECO	1	O	

## II. EXPLODED VIEW AND PART LIST

### 2. BODY ASSEMBLY

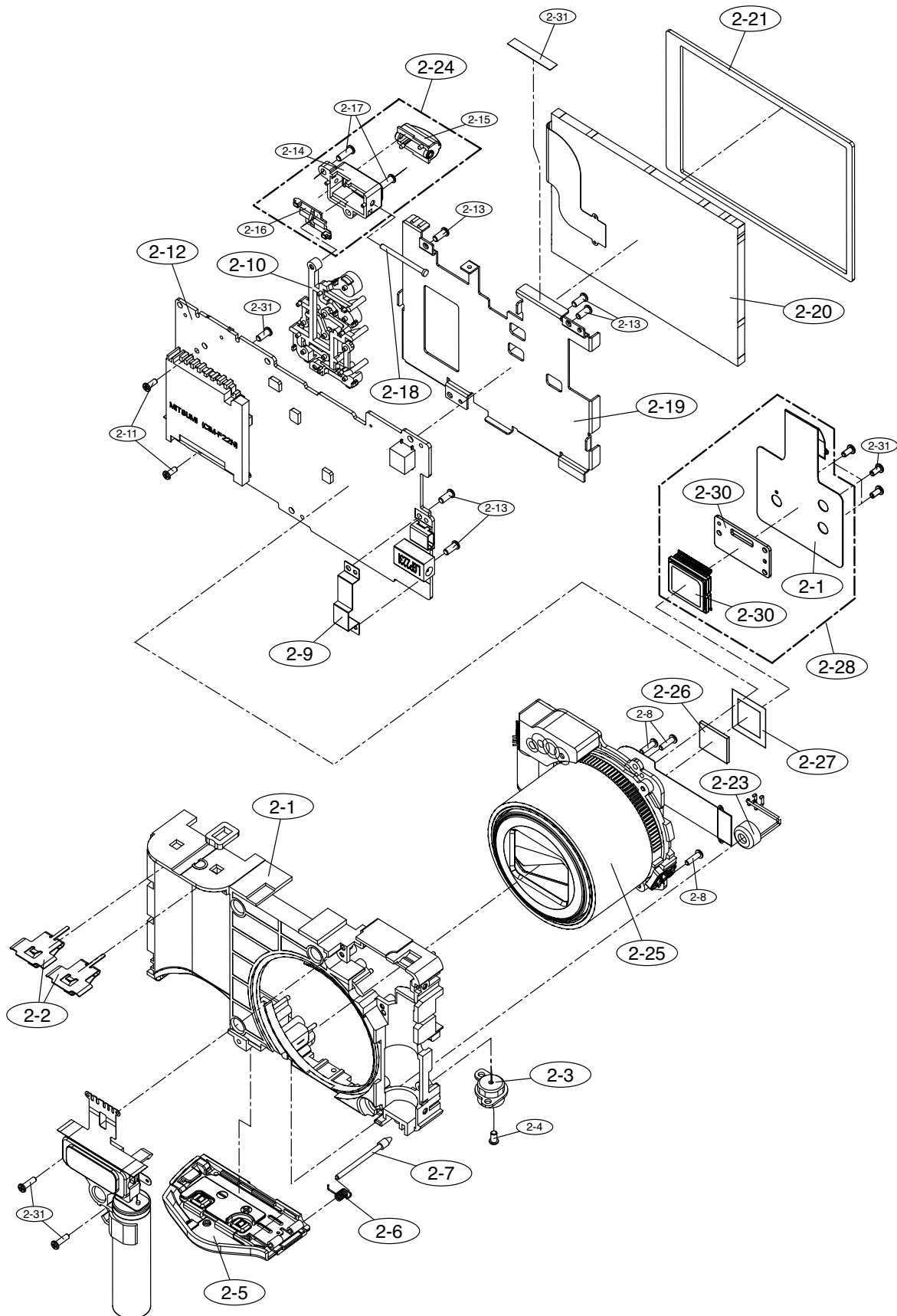



► PARTS LIST

Fig.No	Parts No.	Parts Name	Q'ty	Supply Available Parts	Remarks
2-1	Q7211088602A	BATTERY CHAMBER	1	O	
2-2	Q7011055603A	BATTERY CONTACT(S2_5363)	2	O	
2-3	Q7003000402A	TRIPOD CONNECTOR	1	O	
2-4	Q9761173012	SCREW	1	X	
2-5	Q9007278601A	BATTERY COVER ASSY	1	O	BLACK
	Q9007278601B	BATTERY COVER ASSY	1	O	SILVER
	Q9007278601C	BATTERY COVER ASSY	1	O	PATTEN SILVER
2-6	Q6107074501A	BATTERY HINGE SPRING_S3_73	1	O	
2-7	Q7004002701A	BATTERY HINGE	1	O	
2-8	Q6003018501A	SCREW	5	X	
2-9	Q7011060301A	USB PLATE	1	O	
2-10	Q7211088502A	BACK KEY ACTUATOR	1	O	
2-11	Q0961900301A	SCREW	2	X	
2-12	Q9008115501A	MAIN PCB ASSY	1	O	
2-13	Q9761174007	SCREW	6	X	
2-14	Q7217399101A	ZOOM LEVER HOLDER	1	X	
2-15	Q7217399001A	ZOOM LEVER	1	X	
2-16	Q7309051401A	ZOOM RUBBER	1	X	
2-17	Q9761175007	SCREW	2	X	
2-18	Q7004002601A	ZOOM LEVER HINGE	1	X	
2-19	Q7011060001A	LCD FRAME	1	O	
2-20	Q0704013701A	LCD	1	O	
2-21	Q7409267901A	LCD WINDOW CUSHION	1	O	
2-22	Q7409267601A	LCD TAPE	1	X	
2-23	Q3003001201A	MIC	1	O	
2-24	Q9007278701A	ZOOM LEVER ASSY	1	O	BLACK
	Q9007278701B	ZOOM LEVER ASSY	1	O	SILVER
2-25	Q9002159801A	BARREL ASSY	1	O	BLACK
	Q9002169101A	BARREL ASSY	1	O	SILVER
2-26	Q2904004101A	IR CUT FILTER	1	O	
2-27	Q7309051202A	OLPF CUSHION	1	O	
2-28	Q9008116101A	CCD FPCB ASS'Y SMD	1	O	
2-29	Q7012094301A	CCD PLATE	1	O	
2-30	Q0604007101A	CCD	1	X	
2-31	Q0961900301A	SCREW	3	X	

3. BARREL ASSEMBLY

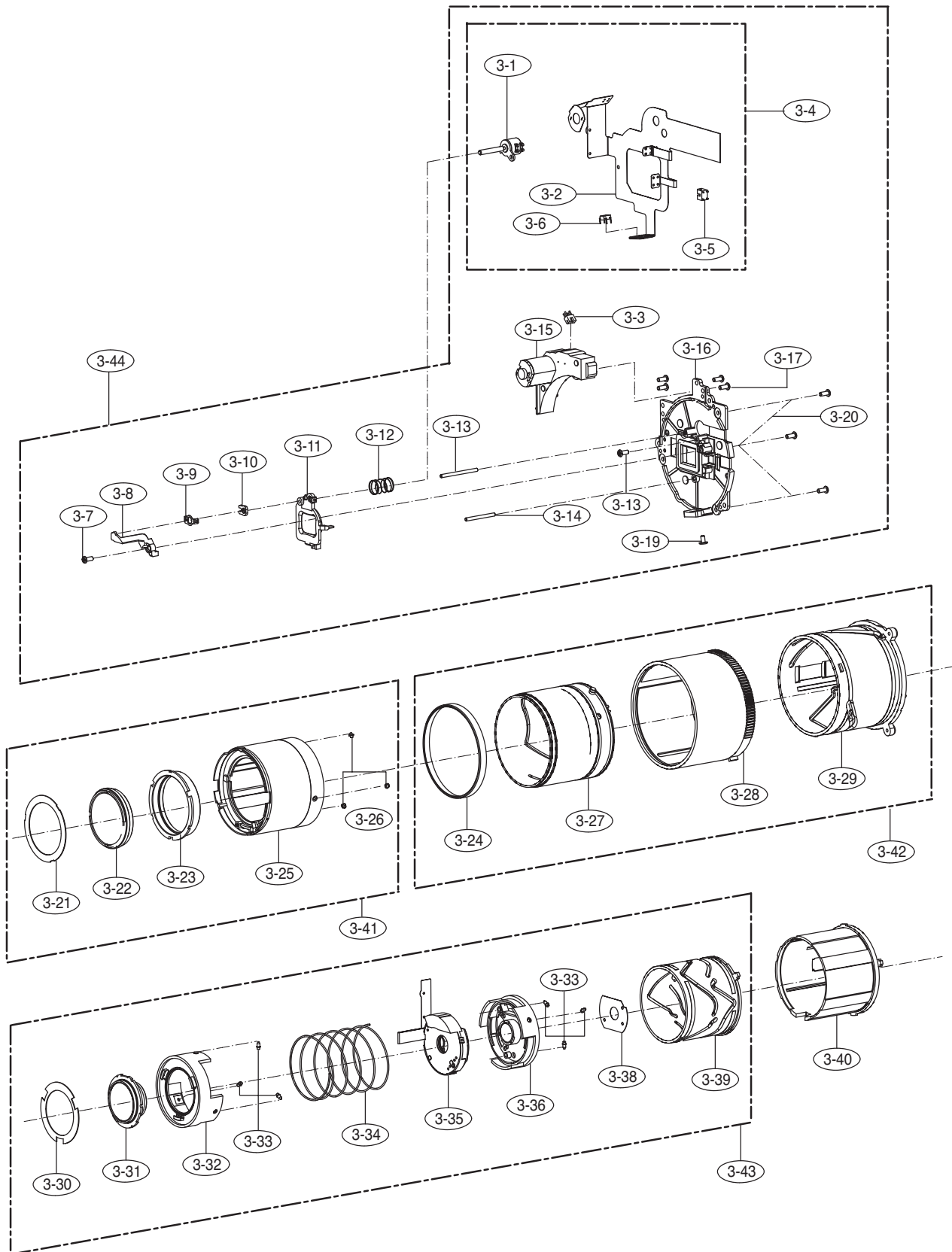

► PARTS LIST

Fig.No	Parts No.	Parts Name	Q'ty	Supply Available Parts	Remarks
3-1	Q9002145901A	AF MOTOR ASS'Y	1	X	
3-2	Q4101039101A	MAIN_F-PCB	1	X	
3-3	Q0608001301A	PHOTO INTERRUPTER SHARP	1	X	
3-4	Q9002159601A	MAIN_F-PCB_ASSY	1	O	
3-5	Q0608001001A	PHOTO INTERRUPTER	1	X	
3-6	Q9002159801A	BARREL_ASSY	1	X	
3-7	Q0961900301A	SCREW	1	X	
3-8	Q7212192602A	AF GUIDE HOLDER	1	O	
3-9	Q7012080802A	AF CLIP HOLDER	1	O	
3-10	Q7012080702A	AF CLIP	1	O	
3-11	Q9002143201A	4TH BARREL ASS'Y	1	O	
3-12	Q6107066401A	4TH LENS SPRING	1	O	
3-13	Q7411121802A	AF GUIDE BAR - A	1	O	
3-14	Q7411121901A	AF GUIDE BAR - B	1	O	
3-15	Q9002158801A	ZOOM_GEAR_ASSY	1	O	
3-16	Q7212201402A	LENS_BASE	1	O	
3-17	Q0961900301A	SCREW	4	X	
3-18	Q0961900301A	SCREW	1	X	
3-19	Q0994913101A	SCREW	1	X	
3-20	Q0961900301A	SCREW	3	X	

## II . EXPLODED VIEW AND PART LIST

---

### ► PARTS LIST

Fig.No	Parts No.	Parts Name	Q'ty	Supply Available Parts	Remarks
3-21	Q7409208602B	1ST SHIELD	1	X	
3-22	Q9002142901A	1ST BARREL ASS'Y	1	X	
3-23	Q7212192101A	SLIP RING	1	X	
3-24	Q7012094101A	CAM_DECO_RING	1	X	
3-25	Q7212197502A	ZOOM_RING	1	X	
3-26	Q7411110404A	1ST MOVE PIN	3	X	
3-27	Q7212197401A	CAM BARREL	1	X	
3-28	Q9002160001A	OUTER_GUIDE_BARREL_ASSY	1	O	
3-29	Q7212191504B	OUTER_CAM_BARREL	1	O	
3-30	Q7409208702B	2ND SHIELD	1	X	
3-31	Q9002143001A	2ND BARREL ASS'Y	1	X	
3-32	Q7212192005A	2ND MOVE BARREL	1	X	
3-33	Q7411121704A	2ND MOVE PIN	3	X	

► PARTS LIST

Fig.No	Parts No.	Parts Name	Q'ty	Supply Available Parts	Remarks
3-34	Q6107066103B	2ND LENS SPRING	1	X	
3-35	Q9005163201A	SHUTTER ASS'Y	1	X	
3-36	Q9002143101A	3RD BARREL ASS'Y	1	X	
3-37	Q7411121704A	2ND MOVE PN	3	X	
3-38	Q7012088701A	3RD LIGHT SHIELD	1	X	
3-39	Q7212191901A	INNER CAM BARREL	1	X	
3-40	Q7212191801B	GUIDE BARREL	1	O	
3-41	Q9002148501A	ZOOM RING ASS'Y	1	O	BLACK
	Q9002155801A	ZOOM RING ASS'Y	1	O	SILVER
3-42	Q9002160101A	CAM_BARREL_ASS'Y	1	O	BLACK
	Q9002155701A	CAM_BARREL_ASS'Y	1	O	SILVER
3-43	Q9002148101A	INNER CAM BARREL ASS'Y	1	O	
3-44	Q9002159301A	LENS_BASE_ASS'Y	1	O	

### 4. BARRIER ASSEMBLY

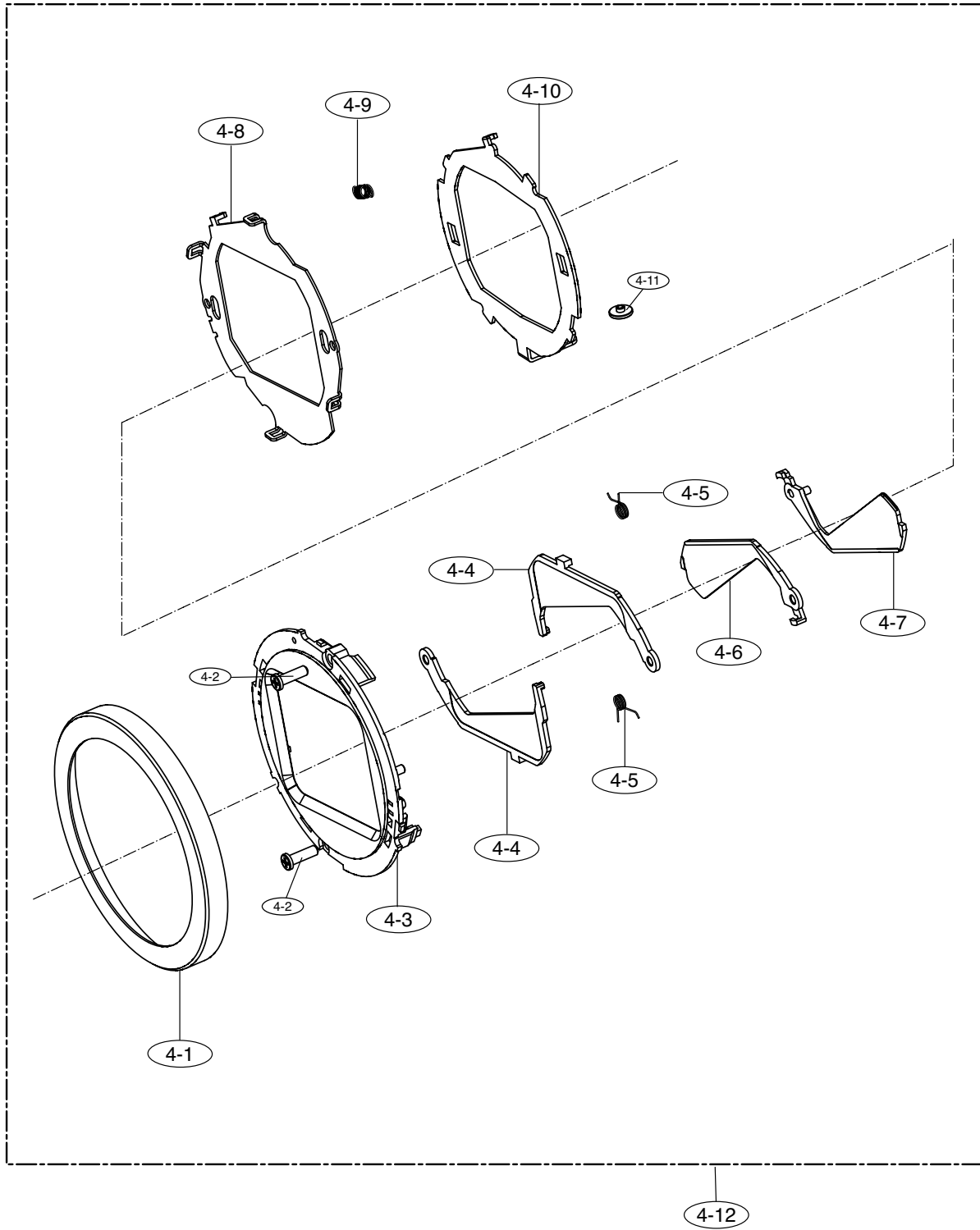

► PARTS LIST

Fig.No	Parts No.	Parts Name	Q'ty	Supply Available Parts	Remarks
4-1	Q7012094001A	DECORATION_RING	1	O	BLACK
	Q7012098101A	DECORATION_RING	1	O	SILVER
4-2	Q6003048701A	BARRIER SCREW-A	2	X	
4-3	Q7212192805A	FRONT PANEL	1	O	
4-4	Q7212193102A	BARRIER C	2	O	
4-5	Q6107066302A	BARRIER_CLOSE_SPRING	2	O	
4-6	Q7212192902A	BARRIER A	1	O	
4-7	Q7212193002A	BARRIER B	1	O	
4-8	Q7012087703B	BARRIER BASE	1	O	
4-9	Q6107066201A	BARRIER OPEN SPRING	1	O	
4-10	Q7012087802A	BARRIER LEVER	1	O	
4-11	Q7411122503A	BARRIER LEVER PIN	1	X	
4-12	Q9002145201A	BARRIER ASSY	1	O	

## 5. STROBO ASSEMBLY

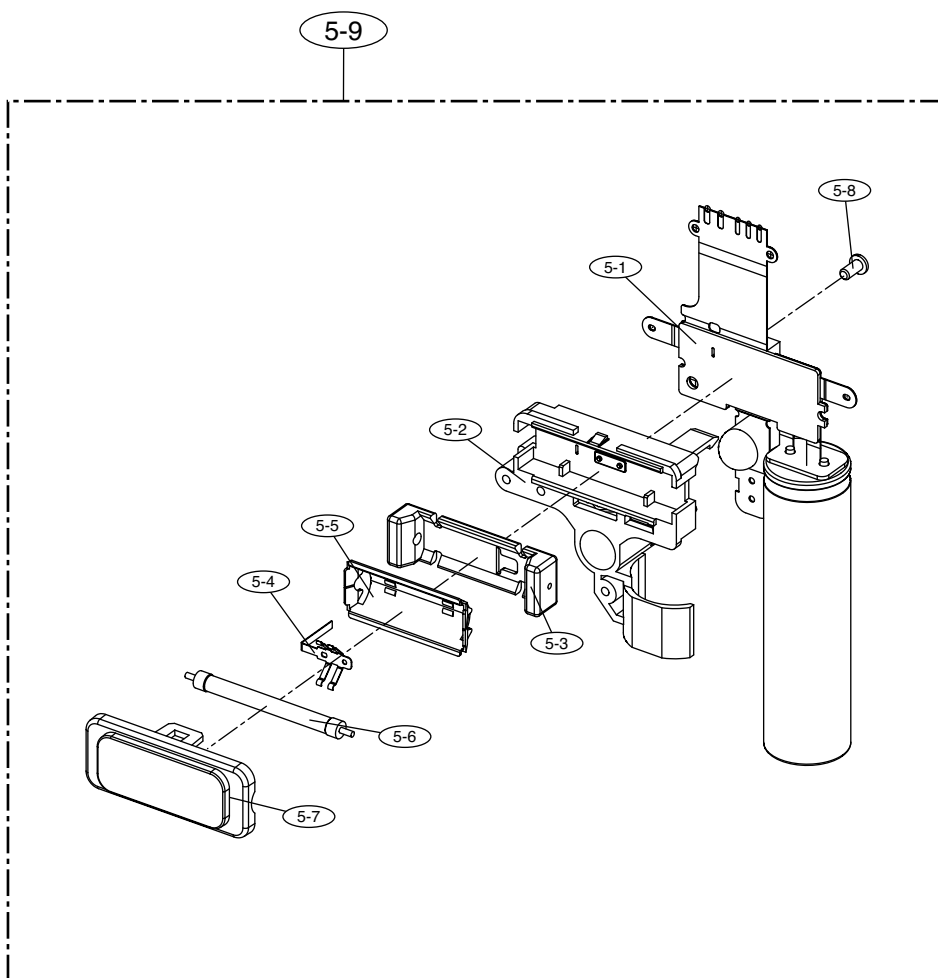



► PARTS LIST

Fig.No	Parts No.	Parts Name	Q'ty	Supply Available Parts	Remarks
5-1	Q9008115901A	STROBO FPCB ASS'Y	1	X	
5-2	Q7214091101A	REFLECTOR HOLDER	1	X	
5-3	Q7309048001A	XE TUBE RUBBER	1	X	
5-4	Q7011056002A	TRIGER CONTACT	1	X	
5-5	Q7014004801A	REFLECTOR	1	X	
5-6	Q0611003101A	REF XE TUBE	1	X	
5-7	Q7214091001A	FRESNEL LENS	1	X	
5-8	Q0961900301A	SCREW	2	X	
5-9	Q9001121401A	STROBO ASSY	1	O	

## 6. FRONT COVER ASSEMBLY

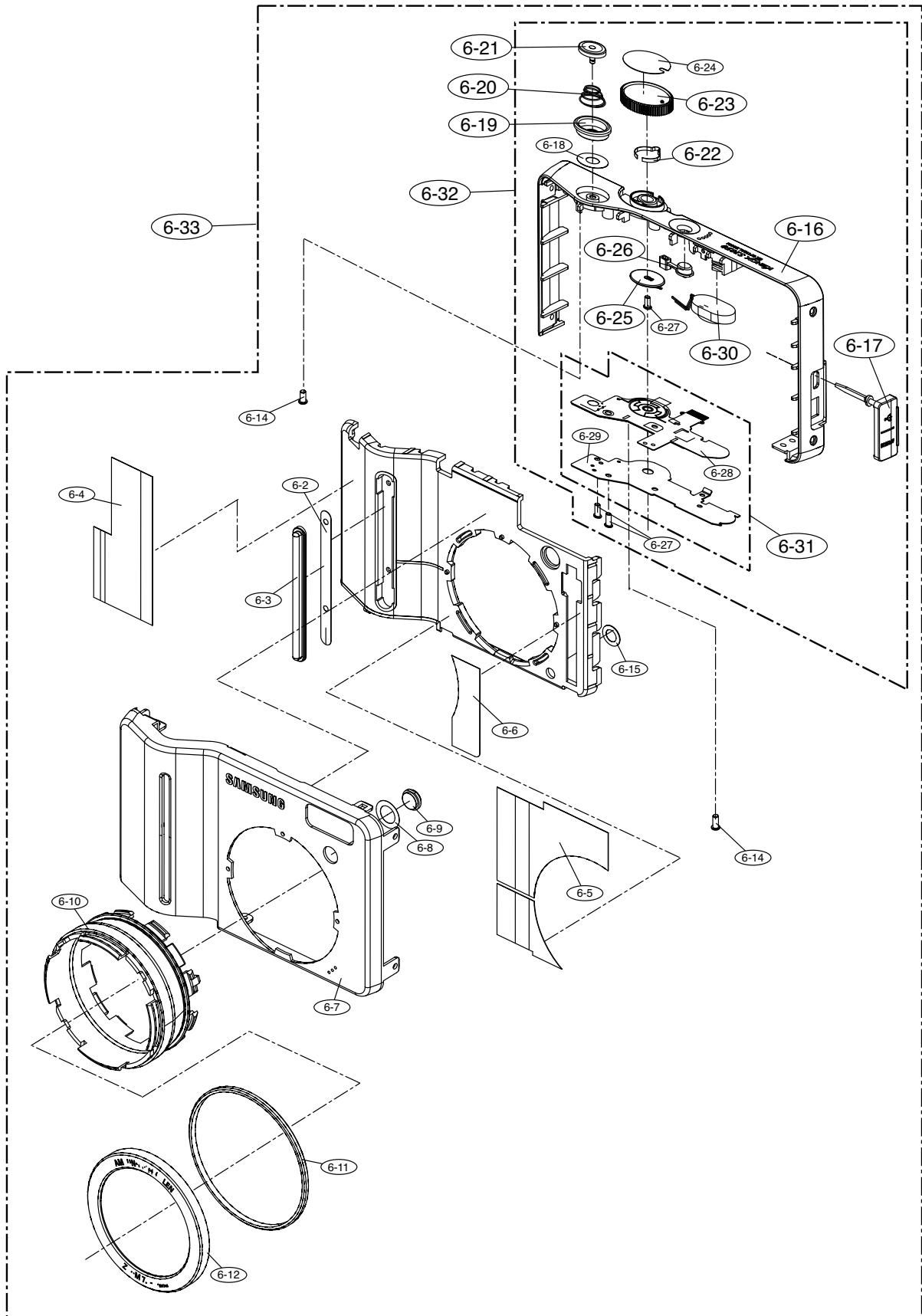

► PARTS LIST

Fig.No	Parts No.	Parts Name	Q'ty	Supply Available Parts	Remarks
6-1	Q7217399501A	FRONT INNER COVER	1	X	
6-2	Q7409268601A	GRIP TAPE	1	X	
6-3	Q7217398501A	GRIP	1	X	
6-4	Q7409268401A	FRONT INNER TAPE B	1	X	
6-5	Q7409268301A	FRONT INNER TAPE A	1	X	
6-6	Q7409269401A	FRONT INNER TAPE C	1	X	
6-7	Q7101003201A	FRONT AL COVER	1	X	
6-8	Q7409268501A	AF LED WINDOW TAPE	1	X	
6-9	Q7217377301A	AF LED WINDOW	1	X	
6-10	Q7217399201C	DECO BARREL	1	X	
6-11	Q7104002301A	DECO BLUE RING	1	X	
6-12	Q7104002201A	DECO FRONT RING	1	X	
6-14	Q9761173512	SCREW	2	X	
6-15	Q7409267701A	MIC SCREEN	1	X	
6-16	Q7217398402A	MIDDLE COVER	1	X	
6-17	Q7309051501A	DC USB COVER BLACK	1	O	BLACK
	Q7309051501B	DC USB COVER BLACK	1	O	SILVER
6-18	Q7409256101A	RELEASE RECO RING TAPE	1	X	
6-19	Q7411123801A	RELEASE DECO RING	1	O	
6-20	Q6107070901A	RELEASE SPRING	1	O	
6-21	Q7217376901A	RELEASE BUTTON	1	O	
6-22	Q7101002301A	MODE DIAL PLATE	1	O	
6-23	Q7217399401A	MODE DIAL	1	O	
6-24	Q7409280801A	MODE DIAL TAPE	1	X	
6-25	Q9007272001A	MODE CONTACT	1	O	
6-26	Q7217399302A	POWER BUTTON	1	O	
6-27	Q9761173512	SCREW	3	X	
6-28	Q9008115701A	TOP KEY FPCB ASSY	1	X	
6-29	Q7011060101A	TOP KEY PLATE	1	X	
6-30	Q3001001501A	SPEAKER	1	O	
6-31	Q9007278501A	TOP KEY PLATE ASSY	1	O	
6-32	Q9007277501A	MIDDLE COVER ASSY KENOX S1050		O	BLACK
	Q9007277501C	MIDDLE COVER ASSY KENOX S1051		O	SILVER
	Q9007277501B	MIDDLE COVER ASSY_SAMSUNG S1050	1	O	BLACK
	Q9007277501D	MIDDLE COVER ASSY_SAMSUNG S1050	1	O	SILVER
6-33	Q9007277201B	FRONT_CONVER_ASSY_SAMSUNG_1050	1	O	BLACK
	Q9007277201D	FRONT_CONVER_ASSY_SAMSUNG_1050	1	O	SILVER
	Q9007277201E	FRONT_CONVER_ASSY_KENOX_1050	1	O	PATTEN BLACK
	Q9007277201F	FRONT_CONVER_ASSY_KENOX_1050	1	O	PATTEN SILVER
	Q9007277201G	FRONT_CONVER_ASSY_SAMSUNG_1050		O	PATTEN SILVER

## 7. REAR COVER ASSEMBLY

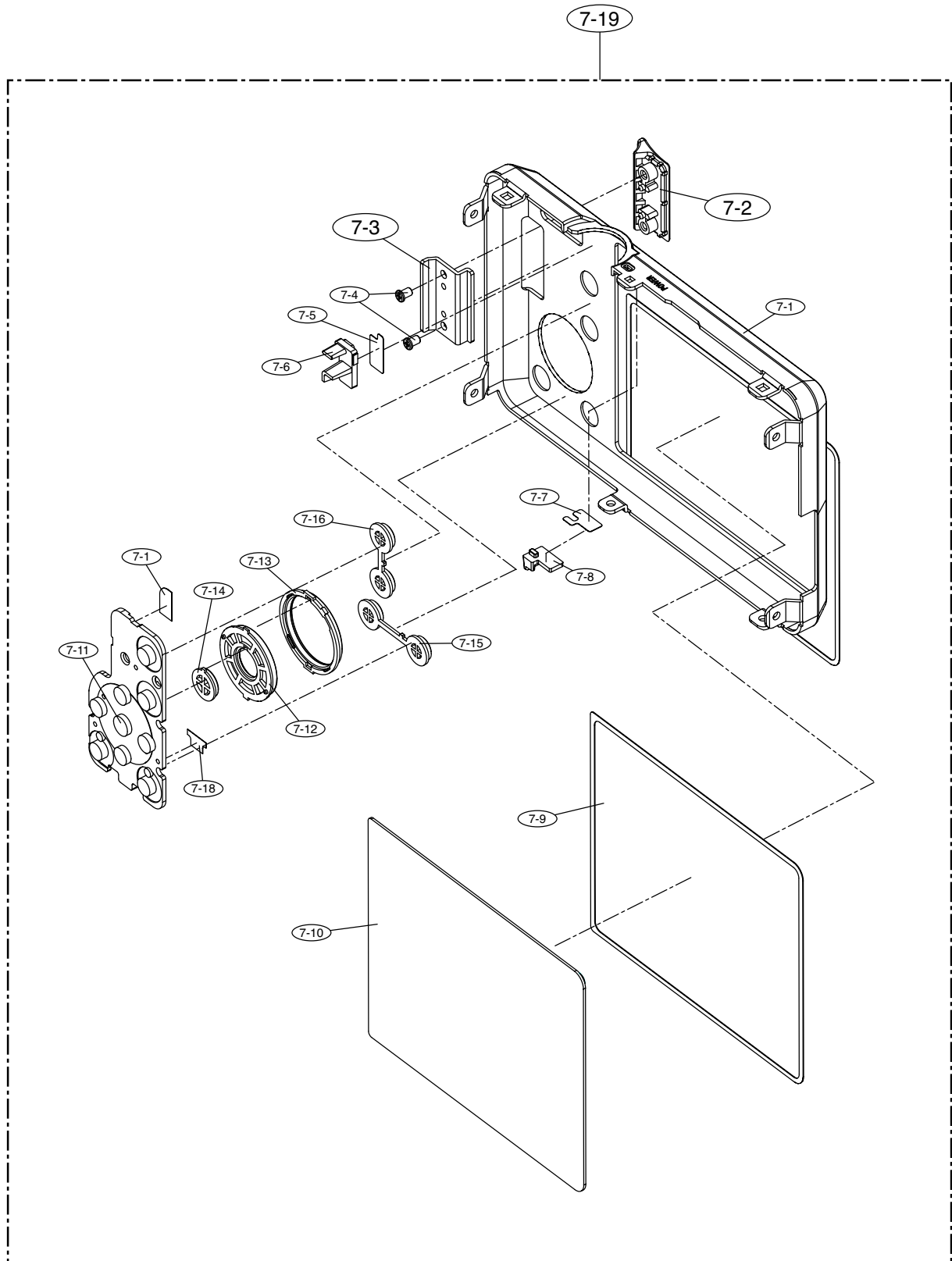

► PARTS LIST

Fig.No	Parts No.	Parts Name	Q'ty	Supply Available Parts	Remarks
7-1	Q7101003301C	BACK AL COVER	1	X	
7-2	Q7103004201A	STRAP HOLDER	1	O	BLACK
	Q7103004201B	STRAP HOLDER	1	O	SILVER
7-3	Q7101003401A	STRAP HOLDER PLATE	1	O	
7-4	Q6001018801A	SCREW	2	X	
7-5	Q7409268001A	BACK LED TAPE	1	X	
7-6	Q7217398001A	BACK LED WINDOW	1	X	
7-7	Q7409268101A	TOP LED TAPE	1	X	
7-8	Q7217397801A	TOP LED WINDOW	1	X	
7-9	Q7409267801A	LCD WINDOW TAPE	1	X	
7-10	Q7217397901A	LCD WINDOW	1	X	
7-11	Q7309051601A	BACK KEY RUBBER	1	X	
7-12	Q7217398701A	NAVI BUTTON	1	X	
7-13	Q7217398801A	NAVI BUTTON DECO	1	X	
7-14	Q7217398901A	OK BUTTON	1	X	
7-15	Q7217403801A	PLAY BUTTON	1	X	
7-16	Q7217398601A	FUNCTION BUTTON	1	X	
7-17	Q7409274901A	BACK KEY TAPE B	1	X	
7-18	Q7409274801A	BACK KEY TAPE A	1	X	
7-19	Q9007277401A	BACK COVER ASS'Y	1	O	BLACK
	Q9007277401B	BACK COVER ASS'Y	1	O	SILVER
	Q9007277401c	BACK COVER ASS'Y	1	O	SILVER PATTERN

8. PACKING ITEM

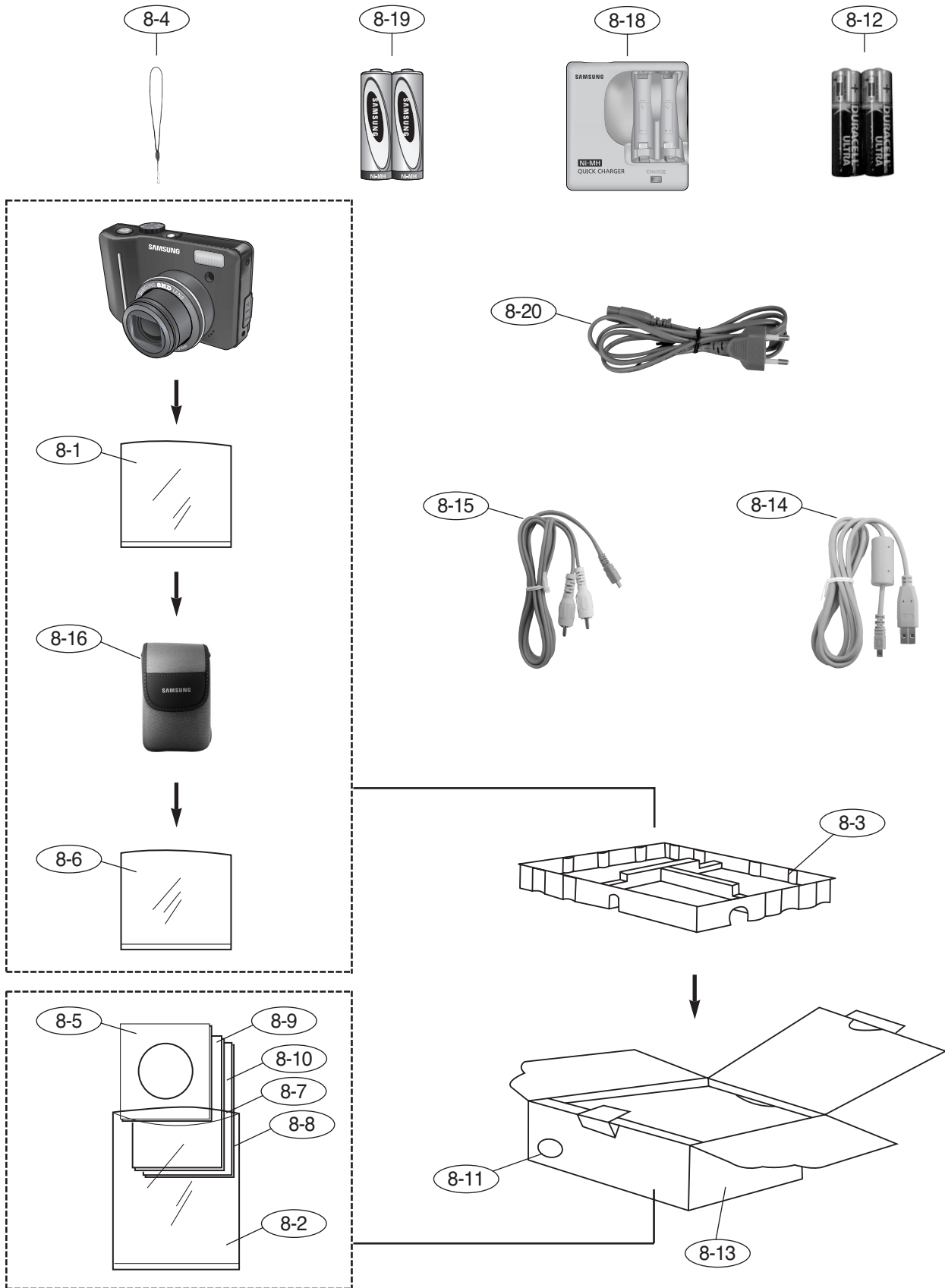

► PARTS LIST

Fig.No	Parts No.	Parts Name	Q'ty	Supply Available Parts	Remarks
8-1	QP960210101A	PE BAG (FOR CAMERA)	1	O	
8-2	Q6909018202A	PE BAG (FOR ACCESSORY)	1	O	
8-3	Q6901266101A	MOLD_PULP_Samsung_S1050_EXP	1	O	
8-4	Q7409271401A	STRAP_KENOX_S730_KOR_EXP	1	O	
8-5	Q4609018301A	DRIVER_DIGIMAX_MASTER_S3-105	1	O	
8-6	Q6909020201A	AIR_BAG_Samsung_S1050_FOR_BODY	1	O	
8-7	Q6909020101A	AIR_BAG_KENOX_S1050	1	O	
	Q6806381001A	Q_GUIDE_KENOX_S1050	1	O	
	Q6806381301A	Q_GUIDE_Samsung_S1050_ENG	1	O	
	Q6806381401A	Q_GUIDE_Samsung_S1050_GER	1	O	
	Q6806381501A	Q_GUIDE_Samsung_S1050_FRA	1	O	
	Q6806381601A	Q_GUIDE_Samsung_S1050_SPA	1	O	
	Q6806381701A	Q_GUIDE_Samsung_S1050_ITA	1	O	
	Q6806381801A	Q_GUIDE_Samsung_S1050_CHI_T	1	O	
	Q6806381901A	Q_GUIDE_Samsung_S1050_DUT	1	O	
	Q6806382001A	Q_GUIDE_Samsung_S1050_POR	1	O	
	Q6806382101A	Q_GUIDE_Samsung_S1050_SWE	1	O	
	Q6806382201A	Q_GUIDE_Samsung_S1050_DEN	1	O	
	Q6806382301A	Q_GUIDE_Samsung_S1050_FIN	1	O	
	Q6806382401A	Q_GUIDE_Samsung_S1050_RUS	1	O	
	Q6806382501A	Q_GUIDE_Samsung_S1050_CHI_S	1	O	
	Q6806382601A	Q_GUIDE_Samsung_S1050_TK	1	O	
	Q6806382701A	Q_GUIDE_Samsung_S1050_IND	1	O	
Q6806382801A	Q_GUIDE_Samsung_S1050_ARA	1	O		
Q6806382901A	Q_GUIDE_Samsung_S1050_THA	1	O		

## II . EXPLODED VIEW AND PART LIST

### ► PARTS LIST

Fig.No	Parts No.	Parts Name	Q'ty	Supply Available Parts	Remarks
8-8	Q6806381101A	U_MANUAL_KENOX_S1050	1	O	
	Q6806383001A	U_MANUAL_Samsung_S1050_ENG	1	O	
	Q6806383101A	U_MANUAL_Samsung_S1050_GER	1	O	
	Q6806383201A	U_MANUAL_Samsung_S1050_FRA	1	O	
	Q6806383301A	U_MANUAL_Samsung_S1050_SPA	1	O	
	Q6806383401A	U_MANUAL_Samsung_S1050_ITA	1	O	
	Q6806383501A	U_MANUAL_Samsung_S1050_CHI_T	1	O	
	Q6806383601A	U_MANUAL_Samsung_S1050_DUT	1	O	
	Q6806383701A	U_MANUAL_Samsung_S1050_POR	1	O	
	Q6806383801A	U_MANUAL_Samsung_S1050_SWE	1	O	
	Q6806383901A	U_MANUAL_Samsung_S1050_DEN	1	O	
	Q6806384001A	U_MANUAL_Samsung_S1050_FIN	1	O	
	Q6806384101A	U_MANUAL_Samsung_S1050_RUS	1	O	
	Q6809006601A	U_MANUAL_ROHS_CHI	1	O	
	Q6806384201A	U_MANUAL_Samsung_S1050_CHI_S	1	O	
	Q6806384301A	U_MANUAL_Samsung_S1050_TK	1	O	
	Q6806384401A	U_MANUAL_Samsung_S1050_IND	1	O	
	Q6806384501A	U_MANUAL_Samsung_S1050_ARA	1	O	
	Q6806384601A	U_MANUAL_Samsung_S1050_THA	1	O	
8-9	Q6806381201A	QS_MANUAL_KENOX_S1050	1	O	
	Q6806384701A	QS_MAN_S1050_E_G_F_SP_I_DU_P_7	1	O	
	Q6806384801A	QS_MAN_S1050_E_G_FI_SW_DA_RU_6	1	O	
	Q6806384901A	QS_MAN_S1050_E_TU_CH_IN_AR_TH_6	1	O	
	Q6806385001A	QS_MAN_S1050_EN_SP_FR_3	1	O	



► PARTS LIST

Fig.No	Parts No.	Parts Name	Q'ty	Supply Available Parts	Remarks
8-10	QP955150101F	WARRANTY CARD_KOREA	1	O	
	Q6807003003U	WARRANTY CARD_EXP	1	O	
	Q6807012301A	WARRANTY CARD_2 YERARS	1	O	
	Q6807010903C	WARRANTY CARD_RUS(3 YEARS)	1	O	
	Q6807011301B	WARRANTY CARD_TSOE(CHINA)	1	O	
	Q6807009502E	CARD_PRODUCT(Mexico)	1	O	
	Q6807012101A	WARRANTY CARD_IRAN	1	O	
8-11	Q6807012401A	WARRANTY CARD_TURKEY	1	O	
	Q6901266601A	GT_BOX_KENOX_S1050_SBC-N2_BLACK	1	O	
	Q6901266701A	GT_BOX_S1050_EXP_AUS_ALKALINE_Black	1	O	
	Q6901266801A	GT_BOX_S1050_USA_CAN_ALKALINE_Black	1	O	
8-12	Q6901273301A	GT_BOX_KENOX_S1050_PATTERN_SL	1	O	
	Q4301001801A	ALKALINE (1.5V, AA) 2EA - DURACEL ULTRA	1	O	
8-13	Q6804110401A	GT_COLOR_STICKER_Silver	1	O	
	Q6804129001A	GT_COLOR_S1050_PATTERN_SILVER	1	O	
	Q6804128801A	GT_COLOR_S1050_PATTERN_BLACK	1	O	
8-14	Q3802006601A	USB CABLE_S730	1	O	
8-15	Q3802006701A	AV CABLE_S730	1	O	
8-16	Q6904031001A	POUCH_Kenox S850_BLACK	1	O	
	Q6904032401A	POUCH_KENOX_S1050_SILVER	1	O	
8-17	Q4302000901A	BATTERY_SNB-2512(AA Type)	1	O	
8-18	Q4309002301A	Ni-MH CHARGER(SBC-N2)	1	O	
8-19	Q6806368001A	MANUAL_SNB-2512B KIT_KOR	1	O	
8-20	Q3801003001A	AC CODE CABLE_KOR-D1	1	O	

### III . ADJUSTMENT

---

#### 1. FIRMWARE

##### 1) Reseting Camera

1. Turn on the Camera

2. Press and hold the UP button and Shutter button and then press the Power button.



3. Turn on the camera and check whether the camera is reset or not.



### III . ADJUSTMENT

---

#### 2) Checking version

1. Remove the memory card from the camera.



2. Turn on the camera.



3. Turn on the camera and press the Up button twice.



4. Press the 5 function button as following order. (Left button → Right button → Down button → +/- button)



### III . ADJUSTMENT

---

5. After pressing the buttons, Firmware version will be displayed



## 3) Upgrading

1. Insert the SD card that has the firmware and turn on the camera.



\* Updating the firmware will delete all data in the SD card.  
Be sure to download all data to your PC before updating the firmware.  
The firmware file name must be " STS3105.ELF "

2. Use the AC adapter or fully charged battery.  
To upgrade the Firmware, all of the battery level indicator on the LCD monitor must be displayed.

3. Turn on the camera.



### III . ADJUSTMENT

---

4. Press the Up button twice to select the Voice recording mode



5. Press the 5 function button as following order. (Left button → Right button → Up button → +/- button)

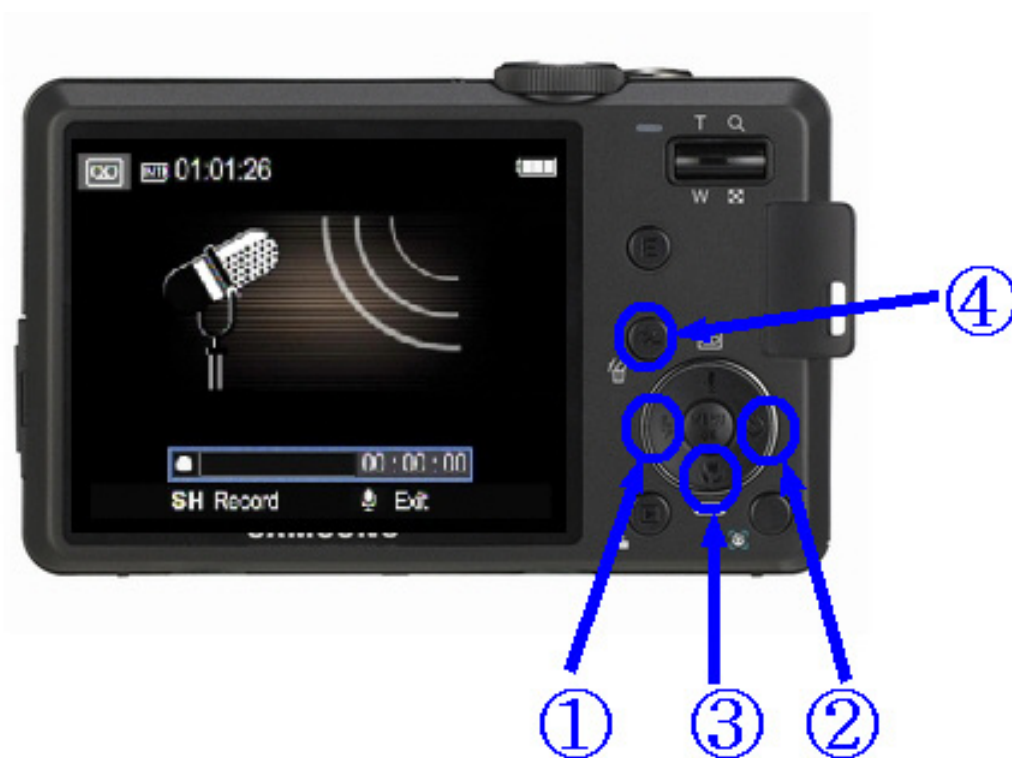



6. After pressing the buttons, Firmware upgrading is shown and then the firmware will be upgraded.  
(For about 30 seconds. Camera status lamp : blinking)



7. After upgrading the firmware, the camera will be turned off automatically.

8. Turn on the camera and do the 'Reset' menu in the Setup menu

### III . ADJUSTMENT

---

#### 4) Full Version of Firmware

How to do the Full Version of Firmware

Depend on the camera status If the Full version of Firmware is needed, upgrade the Full Version of Firmware.

- ▷ **Camera Status** : When turning on the camera, the power consumption (Checking the POWER SUPPLY) is 200-300mA and the camera can't be operated
- ▷ **Cause** : The data of 0 address in the FLASH MEMORY of the MAIN PCB is damaged
- ▷ **Solution** : Recover the address by doing the FULL VERSION FIRMWARE shown below.
- ▷ **Additions** : After completing the upgrading of the FULL VERSION FIRMWARE, do the LENS SHADING and CCD DEFECT CELL adjustment.
- ▷ **Information** :
  - The Full Version of Firmware deletes all the files saved in the camera and newly install the firmware.
  - After Full Version of Firmware, all the adjusted data is deleted that the back up and upload of data is needed.
  - The previous adjusted data will be saved in SD card automatically when updating Full Version of firmware and after updating completed, upload the file
  - Check the back up files CLUT0.BIN, DefectivePixel0.bin and DefectivePixel1.bin at the SD card which are previous adjusted data.

1. Insert the SD card that has the Full version of firmware.



\* Back up all the datas in the Flash memory cause all the data will be erased while updating Full version of firmware. The firmware file name must be "STS3105\_FULL.ELF".

2. Use the AC adapter or fully charged battery.

All of the battery level indicator on the LCD monitor must be displayed.

3. Turn on the camera.

4. Press the Up button twice to select the Voice recording mode.



5. Press the 5 function button as following order. (Left button → Right button → Down button → +/- button)

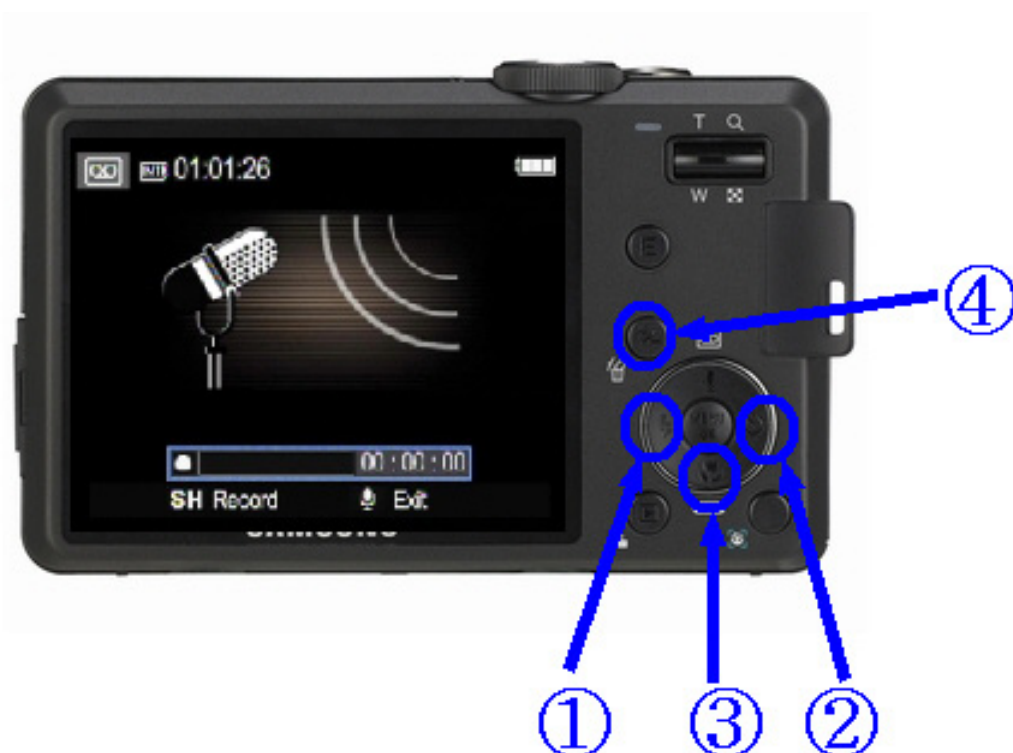

6. After pressing the buttons, Åmessage will display for about 1 minute. (Camera status lamp : blicking)



- While upgrade the Full Version of firmware, the previous data will be saved into the SD card automatically and there should be 3 files LSCLUT0.BIN, DefectivePixel0.bin and DefectivePixel1.bin when the copy is firmly completed.

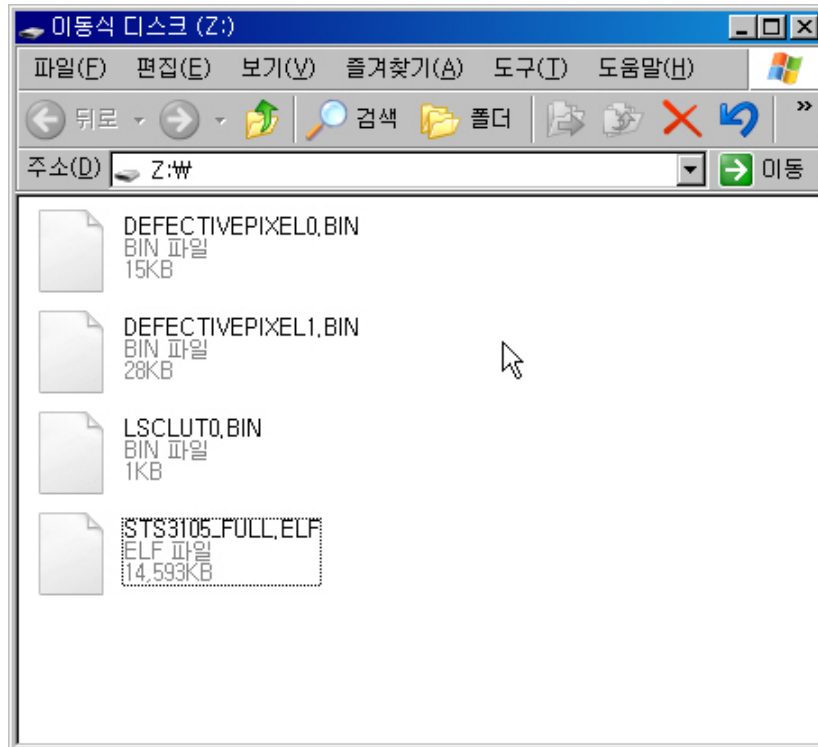

### III . ADJUSTMENT

---

7. After the Full Version of firmware, upload the back up data.

Turn on the camera and press the Up button twice to select the Voice recording mode again.

Press the 4Äfunction button as following order. (Telet button → Wide button → Down button → OK button)



8. The upload will be completed after below message is shown.



9. Turn off the camera.(This time, the camera turns off automatically.)

## 2. ADJUSTMENT CAUTION

### 1) Basic Information of Adjustment

After changing the electronic parts of S1050, the parts have to be adjusted in accordance with the adjusted items. The items listed on the table are have to be adjusted after changing.

1> To adjust the camera after changing the electronic parts, see the below table.

	MAIN PCB	POWER PCB	BARREL ASS' Y	CCD ASS' Y
FIRMWARE UPGRADE	●		●	
PUNT ADJ.	●		●	●
SHUTTER CLOSE TIME ADJ.	●		●	●
BACK LASH ADJ.	●		●	●
FLASH ADJ.	●	●		
BATTERY LEVEL ADJ.	●	●		
OB SETTING	●			●
BURNING TEST & CCD DEFECT CELL	●	●	●	●
EEPROM READ				
EEPROM WRITE				

### 2> Equipment

#### ► Equipments

- AE TESTER : AE TESET can test up to LV 16.7.
- POWER SUPPLY : 3.3V / 2A

#### ► Chart

- Focus Chart
- Gray Chart(18%..Reflection Paper)



3> Adjustment program file

To adjust all items, all kinds of code by items have to be inserted in program file and saved them to the SD card as TXT file type. The codes are listed below

< Description of TXT file >

Use the Memo pad of Basic Windows program and save it as "STS3105ADJ.txt".

```

////////////////////////////////////
// PROJECT : STS3-105
// PROCESS : PM Batch Test 8-process
// DATE : 2007.02.15
////////////////////////////////////

//===== #0. adj control
setting

adj_control check_process_id    65535
adj_control set_process_id     65534
adj_control save_e2prom        1
adj_control save_data_file     1
adj_control save_process_pass  1
adj_control batch              1
adj_control osd_delay          0

adj_control signal             100

//===== #1. OB

delay 5
mode program

adj_ob preview_agc             96
adj_ob preview_target_rgb     0 0 0
adj_ob preview_luma_min_max   1500 4000

adj_ob capture_agc             96
adj_ob capture_target_rgb     0 0 0
adj_ob capture_luma_min_max   1500 4000
adj_ob run

```

### III . ADJUSTMENT

---

```
//delay 5
//adj_control signal 100

//===== #2.LSC

//mode program

adj_lens_shading ng_repeat      3
adj_lens_shading lut_load_percent 80
adj_lens_shading before_capture_skip 1
adj_lens_shading luma_min_max    75 120
adj_lens_shading run

//delay 5

//adj_control signal      100

//===== #3.Battery Level

adj_battery base      211 231

adj_battery half_1  176
adj_battery low_1   170
adj_battery empty_1 166
adj_battery lock_1  162
adj_battery start_1 182

adj_battery half_2  176
adj_battery low_2   169
adj_battery empty_2 165
adj_battery lock_2  161
adj_battery start_2 164
adj_battery run

//===== #4.BackLash

//mode program
//adj_backlash adj_count      2
//adj_backlash max_backlash   85
//adj_backlash run

// Backlash --> burning
Delay 10
//adj_control signal 100
```

```
//===== #5.Shutter Closing

zoom close__to__open
mode program

adj_sh_close max_count      20
adj_sh_close open_init_linedelay  40
adj_sh_close open_init_subdelay   0
adj_sh_close open_linedelay_min_max  35 55

adj_sh_close apt_init_linedelay  43
adj_sh_close apt_init_subdelay   0
adj_sh_close apt_linedelay_min_max 40 60

adj_sh_close iris_skip        0
adj_sh_close iris_adjustrange  6

adj_sh_close gain_skip1       0
adj_sh_close gain_skip2       0

adj_sh_close gain_offset      -3
adj_sh_close gain_setlvalue    208
adj_sh_close gain_adjustrange1 15
adj_sh_close gain_adjustrange2 15

adj_sh_close run

//delay 10
//adj_control signal 100

//===== #6.Strobe

Mode program
Ae metering      1
Ae iso           2
Ae evc          6
Ae preview__fnum  1
Ae preview__s_speed 058
Ae preview__gain  050
Ae lock

//Zoom wide
Delay 10
```

### III . ADJUSTMENT

---

```
adj_strobe_intensity param
adj_strobe_intensity stage      PV2
adj_strobe_intensity flash_table_test  0
adj_strobe_intensity level_test_number 2
adj_strobe_intensity pre_table_index   11 0 0 0 0
adj_strobe_intensity Standard_Luma  190 365 375 720 790 1370
adj_strobe_intensity awb_gain        560 695 280 320
adj_strobe_intensity run

//delay 5
//adj_control signal 100

//===== #7.PUNT

zoom close_to_open      // initialize barrel

mode program
coach idle
ae metering  0          // A* related parameter setting
ae iso       0
ae evc       6
ae preview_fnum 1
set wb auto
coach view
//mode program          // idle -> view
delay 25                // A* convergence delay

adj_punt zoomstep       0 10
adj_punt searching_min_short  307 360 411 460 506 548 573 575 573 574 570
adj_punt searching_max_short  411 460 511 558 604 646 673 679 683 688 690
adj_punt searching_min       105 154 203 250 298 338 359 359 355 352 348
adj_punt searching_max       476 564 613 660 708 748 769 769 765 762 758
adj_punt limit_min_short     317 370 421 470 516 558 583 585 583 584 580
adj_punt limit_max_short     401 450 501 548 594 636 663 669 673 678 680
adj_punt limit_min           135 184 233 280 328 368 389 389 385 382 378
adj_punt limit_max           446 534 583 630 678 718 739 739 735 732 728
adj_punt slop_min            -100 -100 -90 -100 -130 -150 -170 -170 -170 -170
adj_punt slop_max            60 80 100 120 140 160 180 180 180 180
adj_punt run

//delay 5
//adj_control signal 100
```

```
//===== #8.Current
Consumption
mode program
delay 20
zoom wide
delay 30
zoom tele
delay 20
mode playback
delay 10
mode program
poweroff zoom__close
```

```
////////////////////////////////////
// PROJECT : STS3-105
// PROCESS : Backlash / Burnin / Defective Pixel
// DATE : 2007.02.15
////////////////////////////////////

//===== #0. adj control setting

adj_control check_process_id 65532
adj_control set_process_id 65528
adj_control save_e2prom 1
adj_control save_data_file 1
adj_control rePeat_CNT 30
adj_control override_tv_usb 1
adj_control do_check_process_id 1 // check

//===== #1. Backlash

mode program

adj_backlash adj_count 2
adj_backlash max_backlash 85
//adj_backlash integration
adj_backlash run
```

### III . ADJUSTMENT

---

```
delay 20

//===== #2. Burnin Test

adj_burnin delete_all
//adj_burnin format_keep
adj_burnin prog_mode
adj_burnin lcd_on

adj_burnin flash_cap
adj_burnin flash_off_cap
adj_burnin norm_cap
adj_burnin macro_cap

adj_burnin selftimer_cap
adj_burnin play_mode

adj_burnin prog_mode
adj_burnin avi_cap_5sec

adj_burnin easy_mode

adj_burnin aux_led_on
adj_burnin wait_2sec
adj_burnin aux_led_off

adj_burnin burnin_end

//===== #3. CCD Defective Pixel

//start adj_defective_pixel
//adj_control check_process_id 65535
//adj_control save_e2prom 1
//adj_control save_data_file 1

mode program
//ae metering multi
//ae iso 200
//ae ev 0
//ae iris 0
//awb wbal auto
//coach view
//delay 25
```

```
adj_defect integration
adj_defect ref_level_short 800
adj_defect ref_level_long 3500
adj_defect exp_time 6
adj_defect defect_max_num1 30000
adj_defect defect_max_num2 30000
//adj_defect run
//end adj_defect
//delay 10
//poweroff zoom_close
```

※ SD CARD should be formatted at PC.

#### 2) OB SETTING

Judge correctly low level of input signal by doing OB setting about each Preview and Capture and defines validity data area under condition of low brightness condition.

<How to act>

- ① Check the luminance of Preview while shutter is closing and find the OB value base on luminance value of preview.
- ② Write the result of Preview's OB value at the Data file by referencing the information of CARD WRITE
- ③ Write the adjusted value of Preview at the EEPROM by referencing the information of EEPROM WRITE
- ④ Check the luminance of Capture while the shutter is closing and base on that value, find the OB value.
- ⑤ Write the result of Capture's OB adjusted value by referencing the information of CARD WRITE
- ⑥ Write the Capture's adjusted value at the EEPROM by referencing the information of EEPROM WRITE
- ⑦ Change the ISO and repeat the from no.4 to no.6

<How to adjust>

- a...Download program and save it to SD memory card.
- b...Insert the SD memory card that has the program file and turn on the camera.
- c...Adjustment will be done automatically.
- d...After completing the adjustment, the camera is turned off automatically.



<Description of TXT file>

When modify the program, use the Memo Pad of Windows and save it as "STS3105ADJ.txt"

Use only section related to each adjustment.

```

////////////////////////////////////
// PROJECT : STS3-105
// PROCESS : PM Batch Test 8
// DATE : 2007.02.15
////////////////////////////////////

//===== #0. adj control
setting

adj_control check_process_id 65535
adj_control set_process_id 65534
adj_control save_e2prom 1
adj_control save_data_file 1
adj_control save_process_pass 1
adj_control batch 1
adj_control osd_delay 0

adj_control signal 100

//===== #1. OB

delay 5
mode program

adj_ob preview_agc 96
adj_ob preview_target_rgb 0 0 0
adj_ob preview_luma_min_max 1500 4000

adj_ob capture_agc 96
adj_ob capture_target_rgb 0 0 0
adj_ob capture_luma_min_max 1500 4000
adj_ob run

//delay 5
//adj_control signal 100

//===== #2.LSC

//mode program

```

### III . ADJUSTMENT

---

```
adj_lens_shading ng_repeat      3
adj_lens_shading lut_load_percent 80
adj_lens_shading before_capture_skip 1
adj_lens_shading luma_min_max    75 120
adj_lens_shading run

//delay 5

//adj_control signal      100

//===== #3.Battery Level

adj_battery base      211 231

adj_battery half_1    176
adj_battery low_1     170
adj_battery empty_1   166
adj_battery lock_1    162
adj_battery start_1   182

adj_battery half_2    176
adj_battery low_2     169
adj_battery empty_2   165
adj_battery lock_2    161
adj_battery start_2   164
adj_battery run

//===== #4.BackLash

//mode program
//adj_backlash adj_count      2
//adj_backlash max_backlash    85
//adj_backlash run

// Backlash --> burning
Delay 10
//adj_control signal 100

//===== #5.Shutter Closing

zoom close_to_open
mode program
```

```

adj_sh_close max_count          20
adj_sh_close open_init_linedelay 40
adj_sh_close open_init_subdelay  0
adj_sh_close open_linedelay_min_max 35 55

adj_sh_close apt_init_linedelay  43
adj_sh_close apt_init_subdelay    0
adj_sh_close apt_linedelay_min_max 40 60

adj_sh_close iris_skip           0
adj_sh_close iris_adjustrange    6

adj_sh_close gain_skip1          0
adj_sh_close gain_skip2          0

adj_sh_close gain_offset         -3
adj_sh_close gain_setlvalue      208
adj_sh_close gain_adjustrange1   15
adj_sh_close gain_adjustrange2   15

adj_sh_close run

//delay 10
//adj_control signal 100

//===== #6.Strobe

Mode program
Ae metering          1
Ae iso               2
Ae evc               6
Ae preview_fnum     1
Ae preview_s_speed  058
Ae preview_gain     050
Ae lock

//Zoom wide
Delay 10

adj_strobe_intensity param
adj_strobe_intensity stage      PV2
adj_strobe_intensity flash_table_test 0
adj_strobe_intensity level_test_number 2
adj_strobe_intensity pre_table_index 11 0 0 0 0

```

### III . ADJUSTMENT

---

```
adj_strobe_intensity Standard_Luma 190 365 375 720 790 1370
adj_strobe_intensity awb_gain      560 695 280 320
adj_strobe_intensity run

//delay 5
//adj_control signal 100

//===== #7.PUNT

zoom close_to_open      // initialize barrel

mode program
coach idle
ae metering      0      // A* related parameter setting
ae iso          0
ae evc          6
ae preview_fnum 1
set wb auto
coach view
//mode program      // idle -> view
delay 25            // A* convergence delay

adj_punt zoomstep      0 10
adj_punt searching_min_short 307 360 411 460 506 548 573 575 573 574 570
adj_punt searching_max_short 411 460 511 558 604 646 673 679 683 688 690
adj_punt searching_min      105 154 203 250 298 338 359 359 355 352 348
adj_punt searching_max      476 564 613 660 708 748 769 769 765 762 758
adj_punt limit_min_short   317 370 421 470 516 558 583 585 583 584 580
adj_punt limit_max_short   401 450 501 548 594 636 663 669 673 678 680
adj_punt limit_min        135 184 233 280 328 368 389 389 385 382 378
adj_punt limit_max        446 534 583 630 678 718 739 739 735 732 728
adj_punt slop_min         -100 -100 -90 -100 -130 -150 -170 -170 -170 -170
adj_punt slop_max          60 80 100 120 140 160 180 180 180 180
adj_punt run

//delay 5
//adj_control signal 100

//===== #8.Current
Consumption
mode program
delay 20
zoom wide
delay 30
```

```
zoom tele
delay 20
mode playback
delay 10
mode program
poweroff zoom__close
```

※ SD CARD should be formatted at PC.

#### 3) LENS SHADING

This menu adjust the brightness gaps between center of the lens and around the lens

<How to act>

- ① Do the Lens Shading adjustment while the iris is open and Zoom step is 0.Å
  - \* Set the LV as 8.2 of Light box.
  - \* The position of Light Box is  $10\text{mm} \pm 1\text{mm}$  while the barrel is open.
  - \* The colour temperature of Light box is 3300K.
- ② Write the result of adjustment at the EEPROM by referencing the information of EEPROM WRITE
- ③ Write the result of adjustment at Data file by referencing the information of CARD WRITE
- ④ Set the Maxium and Minium level

<How to adjust>

- a...Prepare AE TESTER can be test up to LV as 8.2.
- b...Download program file and save it to SD memory card.
- c...Insert the SD memory card that has the program file and attach the camera to the AE TESTER.
- d...Attach the camera on the AE METER and set the LV as 8.2.

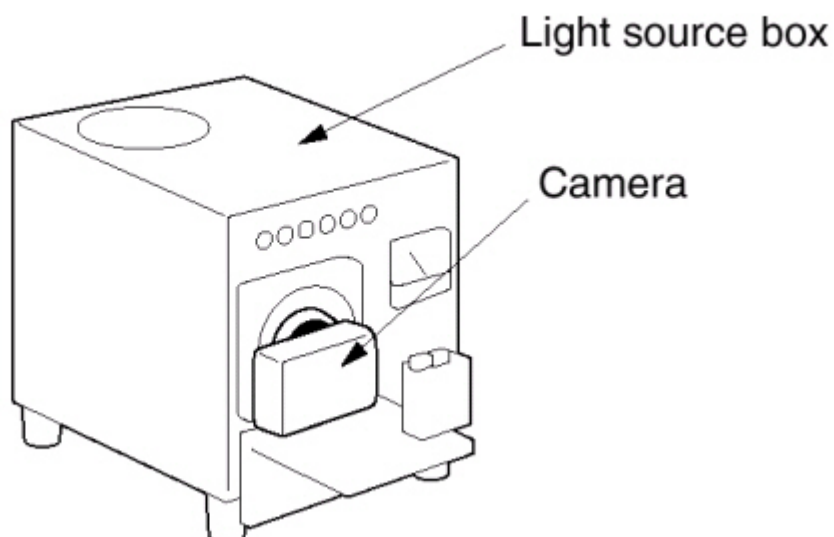

e...Turn on the camera.

f...Adjustment will be done automatically.

e...After completing the adjustment, the camera is turned off automatically.

<Description of TXT file>

When modify the program, use the Memo Pad of Windows and save it as "STS3105ADJ.txt"

Use only section related to each adjustment.

```

////////////////////////////////////
// PROJECT : STS3-105
// PROCESS : PM Batch Test 8
// DATE : 2007.02.15
////////////////////////////////////

//===== #0. adj control
setting

adj_control check_process_id    65535
adj_control set_process_id     65534
adj_control save_e2prom        1
adj_control save_data_file     1
adj_control save_process_pass  1
adj_control batch              1
adj_control osd_delay          0

adj_control signal             100

//===== #1. OB

delay 5
mode program

adj_ob preview_agc             96
adj_ob preview_target_rgb     0 0 0
adj_ob preview_luma_min_max   1500 4000

adj_ob capture_agc             96
adj_ob capture_target_rgb     0 0 0
adj_ob capture_luma_min_max   1500 4000
adj_ob run

```

### III . ADJUSTMENT

---

```
//delay 5
//adj_control signal 100

//===== #2.LSC

//mode program

adj_lens_shading ng_repeat      3
adj_lens_shading lut_load_percent 80
adj_lens_shading before_capture_skip 1
adj_lens_shading luma_min_max    75 120
adj_lens_shading run

//delay 5

//adj_control signal      100

//===== #3.Battery Level

adj_battery base      211 231

adj_battery half_1  176
adj_battery low_1   170
adj_battery empty_1  166
adj_battery lock_1  162
adj_battery start_1  182

adj_battery half_2  176
adj_battery low_2   169
adj_battery empty_2  165
adj_battery lock_2  161
adj_battery start_2  164
adj_battery run

//===== #4.BackLash

//mode program
//adj_backlash adj_count      2
//adj_backlash max_backlash    85
//adj_backlash run

// Backlash --> burning
Delay 10
//adj_control signal 100
```



```
//===== #5.Shutter Closing

zoom close_to_open
mode program

adj_sh_close max_count          20
adj_sh_close open_init_linedelay 40
adj_sh_close open_init_subdelay  0
adj_sh_close open_linedelay_min_max 35 55

adj_sh_close apt_init_linedelay  43
adj_sh_close apt_init_subdelay   0
adj_sh_close apt_linedelay_min_max 40 60

adj_sh_close iris_skip           0
adj_sh_close iris_adjustrange    6

adj_sh_close gain_skip1          0
adj_sh_close gain_skip2          0

adj_sh_close gain_offset         -3
adj_sh_close gain_setlvalue      208
adj_sh_close gain_adjustrange1   15
adj_sh_close gain_adjustrange2   15

adj_sh_close run

//delay 10
//adj_control signal 100

//===== #6.Strobe

Mode program
Ae metering          1
Ae iso                2
Ae evc                6
Ae preview_fnum      1
Ae preview_s_speed   058
Ae preview_gain      050
Ae lock

//Zoom wide
Delay 10
```

### III . ADJUSTMENT

---

```
adj_strobe_intensity param
adj_strobe_intensity stage      PV2
adj_strobe_intensity flash_table_test  0
adj_strobe_intensity level_test_number 2
adj_strobe_intensity pre_table_index   11 0 0 0 0
adj_strobe_intensity Standard_Luma  190 365 375 720 790 1370
adj_strobe_intensity awb_gain        560 695 280 320
adj_strobe_intensity run

//delay 5
//adj_control signal 100

//===== #7.PUNT

zoom close_to_open      // initialize barrel

mode program
coach idle
ae metering      0      // A* related parameter setting
ae iso          0
ae evc          6
ae preview_fnum 1
set wb auto
coach view
//mode program      // idle -> view
delay 25            // A* convergence delay

adj_punt zoomstep      0 10
adj_punt searching_min_short  307 360 411 460 506 548 573 575 573 574 570
adj_punt searching_max_short  411 460 511 558 604 646 673 679 683 688 690
adj_punt searching_min      105 154 203 250 298 338 359 359 355 352 348
adj_punt searching_max      476 564 613 660 708 748 769 769 765 762 758
adj_punt limit_min_short   317 370 421 470 516 558 583 585 583 584 580
adj_punt limit_max_short   401 450 501 548 594 636 663 669 673 678 680
adj_punt limit_min        135 184 233 280 328 368 389 389 385 382 378
adj_punt limit_max        446 534 583 630 678 718 739 739 735 732 728
adj_punt slop_min         -100 -100 -90 -100 -130 -150 -170 -170 -170 -170
adj_punt slop_max         60 80 100 120 140 160 180 180 180 180
adj_punt run

//delay 5
//adj_control signal 100
```

```
//===== #8.Current  
Consumption  
mode program  
delay 20  
zoom wide  
delay 30  
zoom tele  
delay 20  
mode playback  
delay 10  
mode program  
poweroff zoom__close
```

※ SD CARD should be formatted at PC.

### III . ADJUSTMENT

---

#### 4) B/T LEVEL ADJ

After changing the MAIN PCB, adjust WARNING LEVEL and LOCK LEVEL.

<How to adjust>

- a...Prepare the POWER..SUPPLY.
- b...Connect the camera to the POWER..SUPPLY.
- c...Set the voltage to 2.71V.
- d...Downloading the program file and save it to SD memory card.
- e...Insert the SD memory card and turn on the camera.
- f...The adjustment will be done automatically. There are no displays on the LCD.
- g...After completing the upgrade, the camera is turned off automatically.

<Description of TXT file>

When modify the program, use the Memo Pad of Windows and save it as "STS3105ADJ.txt"  
Use only section related to each adjustment.

```
////////////////////////////////////  
// PROJECT : STS3-105  
// PROCESS : PM Batch Test 8  
// DATE : 2007.02.15  
////////////////////////////////////  
  
//===== #0. adj control  
setting  
  
adj_control check_process_id 65535  
adj_control set_process_id 65534  
adj_control save_e2prom 1  
adj_control save_data_file 1
```

```

adj_control save_process_pass 1
adj_control batch 1
adj_control osd_delay 0

adj_control signal 100

//===== #1. OB

delay 5
mode program

adj_ob preview_agc 96
adj_ob preview_target_rgb 0 0 0
adj_ob preview_luma_min_max 1500 4000

adj_ob capture_agc 96
adj_ob capture_target_rgb 0 0 0
adj_ob capture_luma_min_max 1500 4000
adj_ob run

//delay 5
//adj_control signal 100

//===== #2.LSC

//mode program

adj_lens_shading ng_repeat 3
adj_lens_shading lut_load_percent 80
adj_lens_shading before_capture_skip 1
adj_lens_shading luma_min_max 75 120
adj_lens_shading run

//delay 5

//adj_control signal 100

//===== #3.Battery Level

adj_battery base 211 231

adj_battery half_1 176
adj_battery low_1 170
adj_battery empty_1 166
adj_battery lock_1 162
adj_battery start_1 182

```

### III . ADJUSTMENT

---

```
adj_battery half_2 176
adj_battery low_2 169
adj_battery empty_2 165
adj_battery lock_2 161
adj_battery start_2 164
adj_battery run

//===== #4.BackLash

//mode program
//adj_backlash adj_count 2
//adj_backlash max_backlash 85
//adj_backlash run

// Backlash --> burning
Delay 10
//adj_control signal 100

//===== #5.Shutter Closing

zoom close_to_open
mode program

adj_sh_close max_count 20
adj_sh_close open_init_linedelay 40
adj_sh_close open_init_subdelay 0
adj_sh_close open_linedelay_min_max 35 55

adj_sh_close apt_init_linedelay 43
adj_sh_close apt_init_subdelay 0
adj_sh_close apt_linedelay_min_max 40 60

adj_sh_close iris_skip 0
adj_sh_close iris_adjustrange 6

adj_sh_close gain_skip1 0
adj_sh_close gain_skip2 0

adj_sh_close gain_offset -3
adj_sh_close gain_setlvalue 208
adj_sh_close gain_adjustrange1 15
adj_sh_close gain_adjustrange2 15

adj_sh_close run
```

```
//delay 10
//adj_control signal 100

//===== #6.Strobe

Mode program
Ae metering      1
Ae iso           2
Ae evc           6
Ae preview_fnum  1
Ae preview_s_speed 058
Ae preview_gain  050
Ae lock

//Zoom wide
Delay 10

adj_strobe_intensity param
adj_strobe_intensity stage      PV2
adj_strobe_intensity flash_table_test  0
adj_strobe_intensity level_test_number 2
adj_strobe_intensity pre_table_index   11 0 0 0 0
adj_strobe_intensity Standard_Luma 190 365 375 720 790 1370
adj_strobe_intensity awb_gain        560 695 280 320
adj_strobe_intensity run

//delay 5
//adj_control signal 100

//===== #7.PUNT

zoom close_to_open // initialize barrel

mode program
coach idle
ae metering  0 // A* related parameter setting
ae iso      0
ae evc      6
ae preview_fnum 1
set wb auto
coach view
//mode program // idle -> view
delay 25 // A* convergence delay
```

### III . ADJUSTMENT

---

```
adj_punt zoomstep      0 10
adj_punt searching_min_short  307 360 411 460 506 548 573 575 573 574 570
adj_punt searching_max_short  411 460 511 558 604 646 673 679 683 688 690
adj_punt searching_min      105 154 203 250 298 338 359 359 355 352 348
adj_punt searching_max      476 564 613 660 708 748 769 769 765 762 758
adj_punt limit_min_short    317 370 421 470 516 558 583 585 583 584 580
adj_punt limit_max_short    401 450 501 548 594 636 663 669 673 678 680
adj_punt limit_min          135 184 233 280 328 368 389 389 385 382 378
adj_punt limit_max          446 534 583 630 678 718 739 739 735 732 728
adj_punt slop_min           -100 -100 -90 -100 -130 -150 -170 -170 -170 -170
adj_punt slop_max           60 80 100 120 140 160 180 180 180 180
adj_punt run

//delay 5
//adj_control signal 100

//===== #8.Current
Consumption
mode program
delay 20
zoom wide
delay 30
zoom tele
delay 20
mode playback
delay 10
mode program
poweroff zoom_close
```

※ SD CARD should be formatted at PC.



## 5) BACK LASH ADJ

After changing the MAIN PCB, BARREL and CCD, adjust the BACK LASH.

<How to adjust>

- a...Download the Program file and save it to SD memory card.
- b...Insert the SD memory card that has program file and turn on the camera
- c...The adjustment will be done automatically.
- d...After completing the upgrade, the camera is turned off automatically.

<Description of TXT file>

When modify the program, use the Memo Pad of Windows and save it as "STS3105ADJ.txt"  
Use only section related to each adjustment.

```
////////////////////////////////////  
// PROJECT : STS3-105  
// PROCESS : PM Batch Test 8  
// DATE : 2007.02.15  
////////////////////////////////////  
  
//===== #0. adj control  
setting  
  
adj_control check_process_id 65535  
adj_control set_process_id 65534  
adj_control save_e2prom 1  
adj_control save_data_file 1  
adj_control save_process_pass 1  
adj_control batch 1  
adj_control osd_delay 0  
  
adj_control signal 100
```

### III . ADJUSTMENT

---

```
//===== #1. OB

delay 5
mode program

adj_ob preview_agc      96
adj_ob preview_target_rgb  0 0 0
adj_ob preview_luma_min_max  1500 4000

adj_ob capture_agc      96
adj_ob capture_target_rgb  0 0 0
adj_ob capture_luma_min_max  1500 4000
adj_ob run

//delay 5
//adj_control signal 100

//===== #2.LSC

//mode program

adj_lens_shading ng_repeat      3
adj_lens_shading lut_load_percent  80
adj_lens_shading before_capture_skip  1
adj_lens_shading luma_min_max      75 120
adj_lens_shading run

//delay 5

//adj_control signal      100

//===== #3.Battery Level

adj_battery base      211 231

adj_battery half_1  176
adj_battery low_1   170
adj_battery empty_1  166
adj_battery lock_1  162
adj_battery start_1  182

adj_battery half_2  176
adj_battery low_2   169
```

```
adj_battery empty_2      165
adj_battery lock_2      161
adj_battery start_2     164
adj_battery run

//===== #4.BackLash

//mode program
//adj_backlash adj_count      2
//adj_backlash max_backlash   85
//adj_backlash run

// Backlash --> burning
Delay 10
//adj_control signal 100

//===== #5.Shutter Closing

zoom close_to_open
mode program

adj_sh_close max_count      20
adj_sh_close open_init_linedelay  40
adj_sh_close open_init_subdelay   0
adj_sh_close open_linedelay_min_max  35 55

adj_sh_close apt_init_linedelay  43
adj_sh_close apt_init_subdelay   0
adj_sh_close apt_linedelay_min_max 40 60

adj_sh_close iris_skip        0
adj_sh_close iris_adjustrange  6

adj_sh_close gain_skip1       0
adj_sh_close gain_skip2       0

adj_sh_close gain_offset      -3
adj_sh_close gain_setlvalue    208
adj_sh_close gain_adjustrange1  15
adj_sh_close gain_adjustrange2  15

adj_sh_close run

//delay 10
//adj_control signal 100
```

### III . ADJUSTMENT

---

```
//===== #6.Strobe

Mode program
Ae metering      1
Ae iso           2
Ae evc           6
Ae preview__fnum 1
Ae preview__s__speed 058
Ae preview__gain 050
Ae lock

//Zoom wide
Delay 10

adj_strobe__intensity param
adj_strobe__intensity stage      PV2
adj_strobe__intensity flash__table__test 0
adj_strobe__intensity level__test__number 2
adj_strobe__intensity pre__table__index 11 0 0 0 0
adj_strobe__intensity Standard__Luma 190 365 375 720 790 1370
adj_strobe__intensity awb__gain 560 695 280 320
adj_strobe__intensity run

//delay 5
//adj_control signal 100

//===== #7.PUNT

zoom close__to__open // initialize barrel

mode program
coach idle
ae metering 0 // A* related parameter setting
ae iso 0
ae evc 6
ae preview__fnum 1
set wb auto
coach view
//mode program // idle -> view
delay 25 // A* convergence delay

adj_punt zoomstep 0 10
adj_punt searching__min__short 307 360 411 460 506 548 573 575 573 574 570
adj_punt searching__max__short 411 460 511 558 604 646 673 679 683 688 690
adj_punt searching__min 105 154 203 250 298 338 359 359 355 352 348
```

```

adj_punt searching_max      476 564 613 660 708 748 769 769 765 762 758
adj_punt limit_min_short   317 370 421 470 516 558 583 585 583 584 580
adj_punt limit_max_short   401 450 501 548 594 636 663 669 673 678 680
adj_punt limit_min         135 184 233 280 328 368 389 389 385 382 378
adj_punt limit_max         446 534 583 630 678 718 739 739 735 732 728
adj_punt slop_min          -100 -100 -90 -100 -130 -150 -170 -170 -170 -170
adj_punt slop_max          60 80 100 120 140 160 180 180 180 180
adj_punt run

//delay 5
//adj_control signal 100

//===== #8.Current
Consumption
mode program
delay 20
zoom wide
delay 30
zoom tele
delay 20
mode playback
delay 10
mode program
poweroff zoom__close

```

※ SD CARD should be formatted at PC.

### III . ADJUSTMENT

---

#### 6) Iris ADJ

Adjust the step of spertures's differences.

< How to adjust >

a...Prepare AE TESTER can be test up to LV13.

a...Download program file and save it to SD memory card.

c...Insert the SD memory card that has the program file and attach the camera to the AE TESTER.

d...Attach the camera on the AE METER and set the LV as 13.

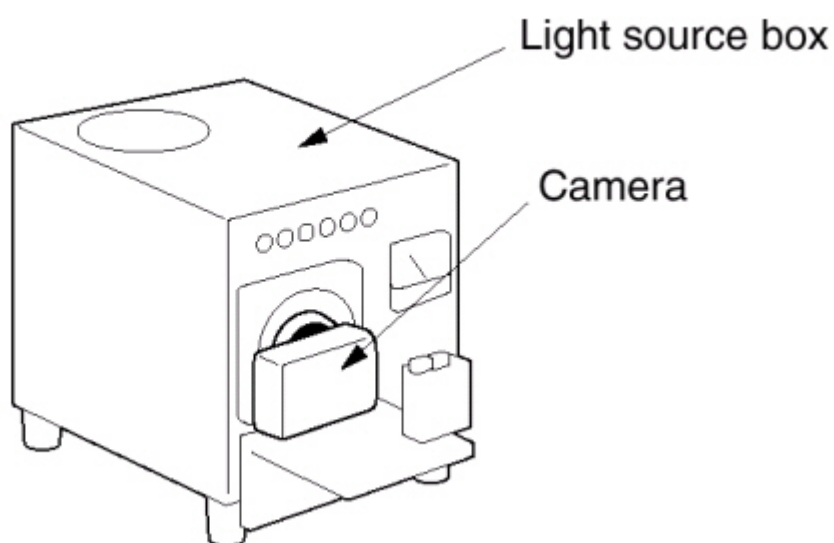

e...Turn on the camera.

f...Adjustment will be done automatically.

e...After completing the adjustment, the camera is turned off automatically.

<Description of TXT file>

When modify the program, use the Memo Pad of Windows and save it as "STS3105ADJ.txt"

Use only section related to each adjustment.

```

////////////////////////////////////
// PROJECT : STS3-105
// PROCESS : PM Batch Test 8
// DATE : 2007.02.15
////////////////////////////////////

//===== #0. adj control
setting

adj_control check_process_id 65535
adj_control set_process_id 65534
adj_control save_e2prom 1
adj_control save_data_file 1
adj_control save_process_pass 1
adj_control batch 1
adj_control osd_delay 0

adj_control signal 100

//===== #1. OB

delay 5
mode program

adj_ob preview_agc 96
adj_ob preview_target_rgb 0 0 0
adj_ob preview_luma_min_max 1500 4000

adj_ob capture_agc 96
adj_ob capture_target_rgb 0 0 0
adj_ob capture_luma_min_max 1500 4000
adj_ob run

//delay 5
//adj_control signal 100

```

### III . ADJUSTMENT

---

```
//===== #2.LSC

//mode program

adj_lens_shading ng_repeat      3
adj_lens_shading lut_load_percent  80
adj_lens_shading before_capture_skip  1
adj_lens_shading luma_min_max      75 120
adj_lens_shading run

//delay 5

//adj_control signal      100

//===== #3.Battery Level

adj_battery base      211 231

adj_battery half_1  176
adj_battery low_1   170
adj_battery empty_1  166
adj_battery lock_1  162
adj_battery start_1  182

adj_battery half_2  176
adj_battery low_2   169
adj_battery empty_2  165
adj_battery lock_2  161
adj_battery start_2  164
adj_battery run

//===== #4.BackLash

//mode program
//adj_backlash adj_count      2
//adj_backlash max_backlash    85
//adj_backlash run

// Backlash --> burning
Delay 10
//adj_control signal 100

//===== #5.Shutter Closing

zoom close_to_open
mode program
```



```
adj_sh_close max_count          20
adj_sh_close open_init_linedelay 40
adj_sh_close open_init_subdelay  0
adj_sh_close open_linedelay_min_max 35 55

adj_sh_close apt_init_linedelay  43
adj_sh_close apt_init_subdelay    0
adj_sh_close apt_linedelay_min_max 40 60

adj_sh_close iris_skip           0
adj_sh_close iris_adjustrange    6

adj_sh_close gain_skip1          0
adj_sh_close gain_skip2          0

adj_sh_close gain_offset         -3
adj_sh_close gain_setlvalue      208
adj_sh_close gain_adjustrange1   15
adj_sh_close gain_adjustrange2   15

adj_sh_close run

//delay 10
//adj_control signal 100

//===== #6.Strobe

Mode program
Ae metering      1
Ae iso           2
Ae evc          6
Ae preview_fnum  1
Ae preview_s_speed 058
Ae preview_gain  050
Ae lock
```

### III . ADJUSTMENT

---

```
//Zoom wide
Delay 10

adj_strobe_intensity param
adj_strobe_intensity stage      PV2
adj_strobe_intensity flash_table_test  0
adj_strobe_intensity level_test_number  2
adj_strobe_intensity pre_table_index   11 0 0 0 0
adj_strobe_intensity Standard_Luma  190 365 375 720 790 1370
adj_strobe_intensity awb_gain        560 695 280 320
adj_strobe_intensity run

//delay 5
//adj_control signal 100

//===== #7.PUNT

zoom close_to_open      // initialize barrel

mode program
coach idle
ae metering  0          // A* related parameter setting
ae iso      0
ae evc      6
ae preview_fnum 1
set wb auto
coach view
//mode program          // idle -> view
delay 25                // A* convergence delay

adj_punt zoomstep      0 10
adj_punt searching_min_short  307 360 411 460 506 548 573 575 573 574 570
adj_punt searching_max_short  411 460 511 558 604 646 673 679 683 688 690
adj_punt searching_min      105 154 203 250 298 338 359 359 355 352 348
adj_punt searching_max      476 564 613 660 708 748 769 769 765 762 758
adj_punt limit_min_short   317 370 421 470 516 558 583 585 583 584 580
adj_punt limit_max_short   401 450 501 548 594 636 663 669 673 678 680
adj_punt limit_min        135 184 233 280 328 368 389 389 385 382 378
adj_punt limit_max        446 534 583 630 678 718 739 739 735 732 728
adj_punt slop_min         -100 -100 -90 -100 -130 -150 -170 -170 -170 -170
adj_punt slop_max         60 80 100 120 140 160 180 180 180 180
adj_punt run
```

```
//delay 5
//adj_control signal 100

//===== #8.Current
Consumption
mode program
delay 20
zoom wide
delay 30
zoom tele
delay 20
mode playback
delay 10
mode program
poweroff zoom_close
```

※ SD CARD should be formatted at PC.

#### 7) SHUTTER CLOSE TIME ADJ

Adjust the Closing timing of machanical shutter.

As the shutter closing time is different depend on the camera set the reduce the differences by adjusting the camera.

<How to act>

- ① Adjust the Shutter closing tiime after checking the number of maxium setting up adjustment.
  - \* The standard luminance of Light box is 13 LV.
  - \* The standard colour temperature of Light box is 3300K.
- ② Do the adjustment by referencing standard luminanace.
  - The Line delay and Sub delay is adjusted to find the proper value at standard luminance.
  - First Line delay and Sube delay value is assigned at the script.
- ③ If the result of Line delay is located between standard minium and maxium value, OK and if not, NG.
- ④ Write the result of adjustment at the EEPROM by referencing the information of EEPROM WRITE.
- ⑤ Write the result of adjustment at the Data file by referencing the information of CARD WRITE.

<How to adjust>

a...Prepare AE TESTER that can be test up to LV 13.

b...Attach the camera to the AE TESTER.

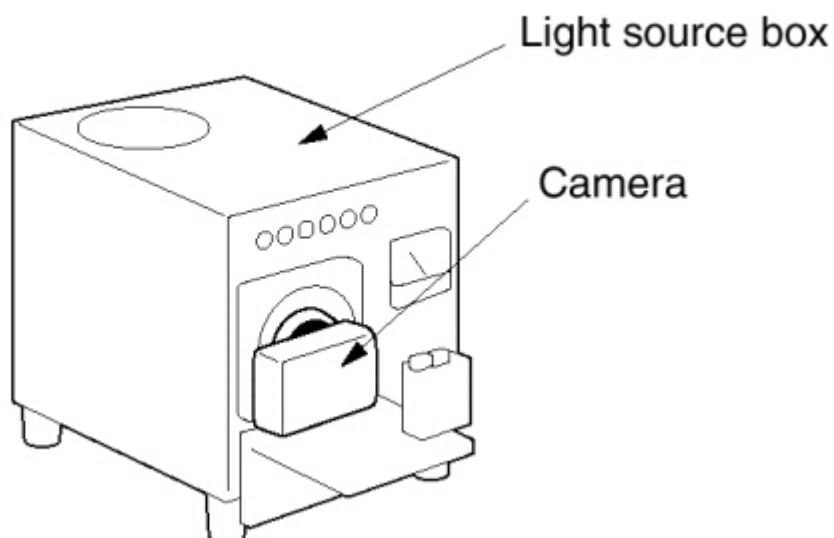

c...Set the LV to 13.

d...Download the program and save it to SD memory card

e...Insert the SD memory card that has the program file and turn on the camera

f...The adjustment will be done automatically.

g...After completing the upgrade, the camera is turned off automatically.

<Description of TXT file>

When modify the program, use the Memo Pad of Windows and save it as "STS3105ADJ.txt"  
Use only section related to each adjustment.

```

////////////////////////////////////
// PROJECT : STS3-105
// PROCESS : PM Batch Test 8
// DATE : 2007.02.15
////////////////////////////////////

//===== #0. adj control
setting

adj_control check_process_id 65535
adj_control set_process_id 65534
adj_control save_e2prom 1
adj_control save_data_file 1
adj_control save_process_pass 1
adj_control batch 1
adj_control osd_delay 0

adj_control signal 100

//===== #1. OB

delay 5
mode program
    
```

### III . ADJUSTMENT

---

```
adj_ob preview_agc      96
adj_ob preview_target_rgb  0 0 0
adj_ob preview_luma_min_max  1500 4000

adj_ob capture_agc      96
adj_ob capture_target_rgb  0 0 0
adj_ob capture_luma_min_max  1500 4000
adj_ob run

//delay 5
//adj_control signal 100

//===== #2.LSC

//mode program

adj_lens_shading ng_repeat      3
adj_lens_shading lut_load_percent  80
adj_lens_shading before_capture_skip  1
adj_lens_shading luma_min_max      75 120
adj_lens_shading run

//delay 5

//adj_control signal      100

//===== #3.Battery Level

adj_battery base      211 231

adj_battery half_1  176
adj_battery low_1   170
adj_battery empty_1  166
adj_battery lock_1  162
adj_battery start_1  182

adj_battery half_2  176
adj_battery low_2   169
adj_battery empty_2  165
adj_battery lock_2  161
adj_battery start_2  164
adj_battery run

//===== #4.BackLash
```

```
//mode program
//adj_backlash adj_count    2
//adj_backlash max_backlash 85
//adj_backlash run

// Backlash --> burning
Delay 10
//adj_control signal 100

//===== #5.Shutter Closing

zoom close_to_open
mode program

adj_sh_close max_count      20
adj_sh_close open_init_linedelay 40
adj_sh_close open_init_subdelay 0
adj_sh_close open_linedelay_min_max 35 55

adj_sh_close apt_init_linedelay 43
adj_sh_close apt_init_subdelay 0
adj_sh_close apt_linedelay_min_max 40 60

adj_sh_close iris_skip      0
adj_sh_close iris_adjustrange 6

adj_sh_close gain_skip1     0
adj_sh_close gain_skip2     0

adj_sh_close gain_offset    -3
adj_sh_close gain_setlvalue 208
adj_sh_close gain_adjustrange1 15
adj_sh_close gain_adjustrange2 15

adj_sh_close run

//delay 10
//adj_control signal 100

//===== #6.Strobe
```

### III . ADJUSTMENT

---

```
Mode program
Ae metering      1
Ae iso           2
Ae evc           6
Ae preview__fnum 1
Ae preview__s__speed 058
Ae preview__gain 050
Ae lock

//Zoom wide
Delay 10

adj_strobe__intensity param
adj_strobe__intensity stage      PV2
adj_strobe__intensity flash__table__test 0
adj_strobe__intensity level__test__number 2
adj_strobe__intensity pre__table__index 11 0 0 0 0
adj_strobe__intensity Standard__Luma 190 365 375 720 790 1370
adj_strobe__intensity awb__gain 560 695 280 320
adj_strobe__intensity run

//delay 5
//adj_control signal 100

//===== #7.PUNT

zoom close__to__open // initialize barrel

mode program
coach idle
ae metering 0 // A* related parameter setting
ae iso 0
ae evc 6
ae preview__fnum 1
set wb auto
coach view
//mode program // idle -> view
delay 25 // A* convergence delay

adj_punt zoomstep 0 10
adj_punt searching__min__short 307 360 411 460 506 548 573 575 573 574 570
adj_punt searching__max__short 411 460 511 558 604 646 673 679 683 688 690
adj_punt searching__min 105 154 203 250 298 338 359 359 355 352 348
```



```

adj_punt searching_max      476 564 613 660 708 748 769 769 765 762 758
adj_punt limit_min_short   317 370 421 470 516 558 583 585 583 584 580
adj_punt limit_max_short   401 450 501 548 594 636 663 669 673 678 680
adj_punt limit_min         135 184 233 280 328 368 389 389 385 382 378
adj_punt limit_max         446 534 583 630 678 718 739 739 735 732 728
adj_punt slop_min          -100 -100 -90 -100 -130 -150 -170 -170 -170 -170
adj_punt slop_max          60 80 100 120 140 160 180 180 180 180
adj_punt run

//delay 5
//adj_control signal 100

//===== #8.Current
Consumption
mode program
delay 20
zoom wide
delay 30
zoom tele
delay 20
mode playback
delay 10
mode program
poweroff zoom_close

```

※ SD CARD should be formatted at PC.

### III . ADJUSTMENT

---

#### 8) CCD GAIN ADJ

Adjust the CCD gain by camera.

< How to adjust >

a...Prepare AE TESTER can be test up to LV13.

b...Download program file and save it to SD memory card.

c...Insert the SD memory card that has the program file and attach the camera to the AE TESTER.

d...Attach the camera on the AE METER and set the LV as 13.

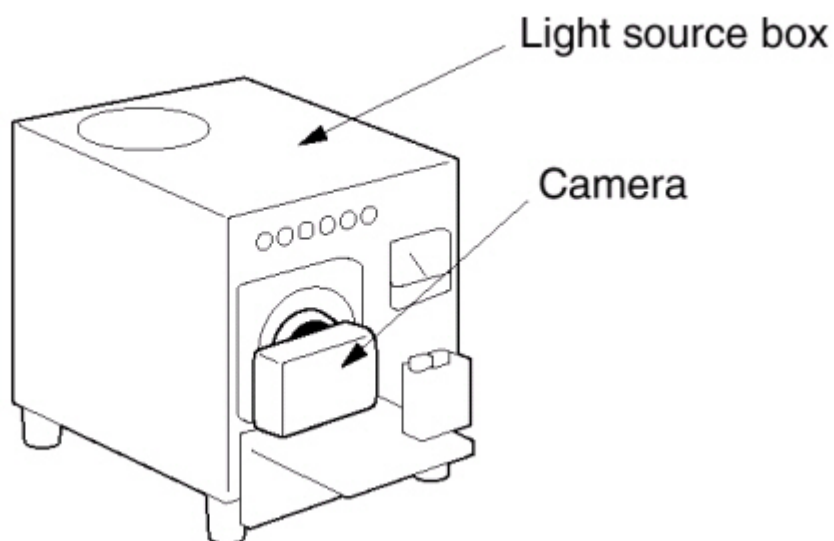

e...Turn on the camera.

f...Adjustment will be done automatically.

e...After completing the adjustment, the camera is turned off automatically.

<Description of TXT file>

When modify the program, use the Memo Pad of Windows and save it as "STS3105ADJ.txt"

Use only section related to each adjustment.

```

////////////////////////////////////
// PROJECT : STS3-105
// PROCESS : PM Batch Test 8
// DATE : 2007.02.15
////////////////////////////////////

//===== #0. adj control
setting

adj_control check_process_id 65535
adj_control set_process_id 65534
adj_control save_e2prom 1
adj_control save_data_file 1

adj_control save_process_pass 1
adj_control batch 1
adj_control osd_delay 0

adj_control signal 100

//===== #1. OB

delay 5
mode program

adj_ob preview_agc 96
adj_ob preview_target_rgb 0 0 0
adj_ob preview_luma_min_max 1500 4000

adj_ob capture_agc 96
adj_ob capture_target_rgb 0 0 0
adj_ob capture_luma_min_max 1500 4000
adj_ob run

//delay 5
//adj_control signal 100

```

### III . ADJUSTMENT

---

```
//===== #2.LSC

//mode program

adj_lens_shading ng_repeat      3
adj_lens_shading lut_load_percent  80
adj_lens_shading before_capture_skip  1
adj_lens_shading luma_min_max      75 120
adj_lens_shading run

//delay 5

//adj_control signal      100

//===== #3.Battery Level

adj_battery base      211 231

adj_battery half_1  176
adj_battery low_1   170
adj_battery empty_1  166
adj_battery lock_1  162
adj_battery start_1  182

adj_battery half_2  176
adj_battery low_2   169
adj_battery empty_2  165
adj_battery lock_2  161
adj_battery start_2  164
adj_battery run

//===== #4.BackLash

//mode program
//adj_backlash adj_count      2
//adj_backlash max_backlash   85
//adj_backlash run

// Backlash --> burning
Delay 10
//adj_control signal 100

//===== #5.Shutter Closing

zoom close_to_open
mode program
```

```

adj_sh_close max_count          20
adj_sh_close open_init_linedelay  40
adj_sh_close open_init_subdelay   0
adj_sh_close open_linedelay_min_max  35 55

adj_sh_close apt_init_linedelay   43
adj_sh_close apt_init_subdelay    0
adj_sh_close apt_linedelay_min_max 40 60

adj_sh_close iris_skip           0
adj_sh_close iris_adjustrange     6

adj_sh_close gain_skip1          0
adj_sh_close gain_skip2          0

adj_sh_close gain_offset         -3
adj_sh_close gain_setlvalue       208
adj_sh_close gain_adjustrange1    15
adj_sh_close gain_adjustrange2    15

adj_sh_close run

//delay 10
//adj_control signal 100

//===== #6.Strobe

Mode program
Ae metering      1
Ae iso           2
Ae evc          6
Ae preview_fnum  1
Ae preview_s_speed 058
Ae preview_gain  050
Ae lock

//Zoom wide
Delay 10

```

### III . ADJUSTMENT

---

```
adj_strobe_intensity param
adj_strobe_intensity stage      PV2
adj_strobe_intensity flash_table_test  0
adj_strobe_intensity level_test_number 2
adj_strobe_intensity pre_table_index   11 0 0 0 0
adj_strobe_intensity Standard_Luma  190 365 375 720 790 1370
adj_strobe_intensity awb_gain        560 695 280 320
adj_strobe_intensity run

//delay 5
//adj_control signal 100

//===== #7.PUNT

zoom close_to_open      // initialize barrel

mode program
coach idle
ae metering  0          // A* related parameter setting
ae iso       0
ae evc       6
ae preview_fnum 1
set wb auto
coach view
//mode program          // idle -> view
delay 25                // A* convergence delay

adj_punt zoomstep      0 10
adj_punt searching_min_short  307 360 411 460 506 548 573 575 573 574 570
adj_punt searching_max_short  411 460 511 558 604 646 673 679 683 688 690
adj_punt searching_min      105 154 203 250 298 338 359 359 355 352 348
adj_punt searching_max      476 564 613 660 708 748 769 769 765 762 758
adj_punt limit_min_short    317 370 421 470 516 558 583 585 583 584 580
adj_punt limit_max_short    401 450 501 548 594 636 663 669 673 678 680
adj_punt limit_min          135 184 233 280 328 368 389 389 385 382 378
adj_punt limit_max          446 534 583 630 678 718 739 739 735 732 728
adj_punt slop_min           -100 -100 -90 -100 -130 -150 -170 -170 -170 -170
adj_punt slop_max           60 80 100 120 140 160 180 180 180 180
adj_punt run
```

```
//delay 5
//adj_control signal 100

//===== #8.Current
Consumption
mode program
delay 20
zoom wide
delay 30
zoom tele
delay 20
mode playback
delay 10
mode program
poweroff zoom_close
```

※ SD CARD should be formatted at PC.

### III . ADJUSTMENT

---

#### 9) FLASH ADJ

Adjust the CCD gain by camera.

< How to adjust >

a...Prepare AE TESTER can be test up to LV13.

b...Download program file and save it to SD memory card.

c...Insert the SD memory card that has the program file and attach the camera to the AE TESTER.

d...Attach the camera on the AE METER and set the LV as 13.

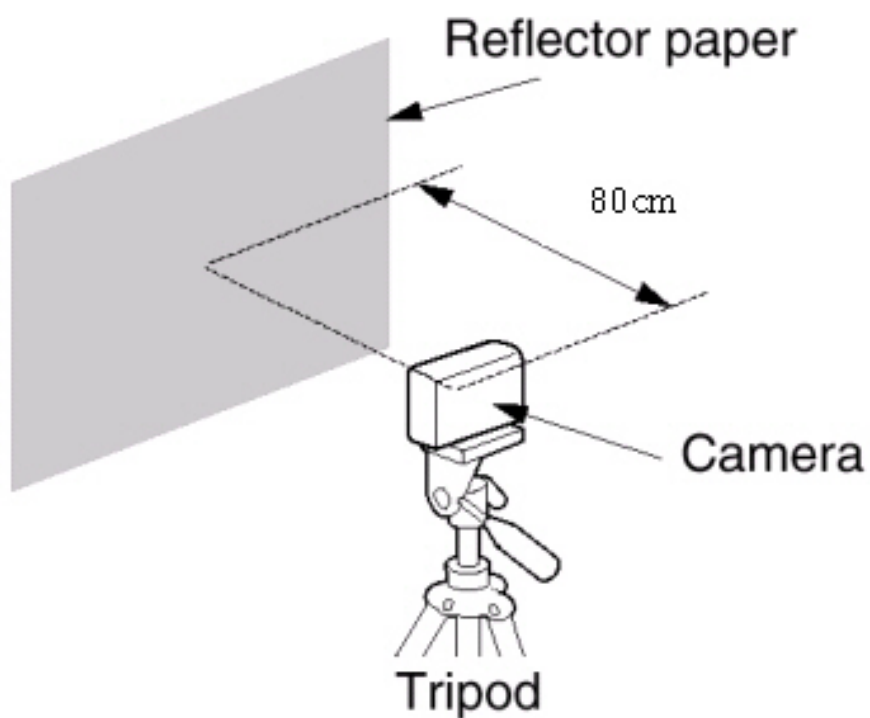

e...Turn on the camera.

f...Adjustment will be done automatically.

e...After completing the adjustment, the camera is turned off automatically.



<Description of TXT file>

When modify the program, use the Memo Pad of Windows and save it as "STS3105ADJ.txt"

Use only section related to each adjustment.

```

////////////////////////////////////
// PROJECT : STS3-105
// PROCESS : PM Batch Test 8
// DATE : 2007.02.15
////////////////////////////////////

//===== #0. adj control
setting

adj_control check_process_id 65535
adj_control set_process_id 65534
adj_control save_e2prom 1
adj_control save_data_file 1
adj_control save_process_pass 1
adj_control batch 1
adj_control osd_delay 0

adj_control signal 100

//===== #1. OB

delay 5
mode program

adj_ob preview_agc 96
adj_ob preview_target_rgb 0 0 0
adj_ob preview_luma_min_max 1500 4000

adj_ob capture_agc 96
adj_ob capture_target_rgb 0 0 0
adj_ob capture_luma_min_max 1500 4000
adj_ob run

//delay 5
//adj_control signal 100

//===== #2.LSC

```

### III . ADJUSTMENT

---

```
//mode program

adj_lens_shading ng_repeat      3
adj_lens_shading lut_load_percent  80
adj_lens_shading before_capture_skip  1
adj_lens_shading luma_min_max      75 120
adj_lens_shading run

//delay 5

//adj_control signal      100

//===== #3.Battery Level

adj_battery base      211 231

adj_battery half_1  176
adj_battery low_1   170
adj_battery empty_1  166
adj_battery lock_1  162
adj_battery start_1  182

adj_battery half_2  176
adj_battery low_2   169
adj_battery empty_2  165
adj_battery lock_2  161
adj_battery start_2  164
adj_battery run

//===== #4.BackLash

//mode program
//adj_backlash adj_count      2
//adj_backlash max_backlash   85
//adj_backlash run

// Backlash --> burning
Delay 10
//adj_control signal 100

//===== #5.Shutter Closing

zoom close_to_open
mode program
```

```

adj_sh_close max_count          20
adj_sh_close open_init_linedelay  40
adj_sh_close open_init_subdelay   0
adj_sh_close open_linedelay_min_max  35 55

adj_sh_close apt_init_linedelay   43
adj_sh_close apt_init_subdelay    0
adj_sh_close apt_linedelay_min_max 40 60

adj_sh_close iris_skip           0
adj_sh_close iris_adjustrange    6

adj_sh_close gain_skip1          0
adj_sh_close gain_skip2          0

adj_sh_close gain_offset         -3
adj_sh_close gain_setlvalue       208
adj_sh_close gain_adjustrange1    15
adj_sh_close gain_adjustrange2    15

adj_sh_close run

//delay 10
//adj_control signal 100

//===== #6.Strobe

Mode program
Ae metering      1
Ae iso           2
Ae evc          6
Ae preview_fnum  1
Ae preview_s_speed 058
Ae preview_gain  050
Ae lock

//Zoom wide
Delay 10

```

### III . ADJUSTMENT

---

```
adj_strobe_intensity param
adj_strobe_intensity stage      PV2
adj_strobe_intensity flash_table_test  0
adj_strobe_intensity level_test_number 2
adj_strobe_intensity pre_table_index   11 0 0 0 0
adj_strobe_intensity Standard_Luma  190 365 375 720 790 1370
adj_strobe_intensity awb_gain        560 695 280 320
adj_strobe_intensity run

//delay 5
//adj_control signal 100

//===== #7.PUNT

zoom close_to_open      // initialize barrel

mode program
coach idle
ae metering  0          // A* related parameter setting
ae iso       0
ae evc       6
ae preview_fnum 1
set wb auto
coach view
//mode program          // idle -> view
delay 25                // A* convergence delay

adj_punt zoomstep      0 10
adj_punt searching_min_short  307 360 411 460 506 548 573 575 573 574 570
adj_punt searching_max_short  411 460 511 558 604 646 673 679 683 688 690
adj_punt searching_min      105 154 203 250 298 338 359 359 355 352 348
adj_punt searching_max      476 564 613 660 708 748 769 769 765 762 758
adj_punt limit_min_short    317 370 421 470 516 558 583 585 583 584 580
adj_punt limit_max_short    401 450 501 548 594 636 663 669 673 678 680
adj_punt limit_min          135 184 233 280 328 368 389 389 385 382 378
adj_punt limit_max          446 534 583 630 678 718 739 739 735 732 728
adj_punt slop_min           -100 -100 -90 -100 -130 -150 -170 -170 -170 -170
adj_punt slop_max           60 80 100 120 140 160 180 180 180 180
adj_punt run
```

```
//delay 5
//adj_control signal 100

//===== #8.Current
Consumption
mode program
delay 20
zoom wide
delay 30
zoom tele
delay 20
mode playback
delay 10
mode program
poweroff zoom_close
```

※ SD CARD should be formatted at PC.

### III . ADJUSTMENT

---

#### 10) FOCUS ADJ

Set up the AF searching range to find the best focusing position by barrel.

< How to adjust >

a...Arrange a chart for adjust the FOCUS.

b...Attach the camera to the tripod.

c...The distance between the chart and the camera should be 80cm.

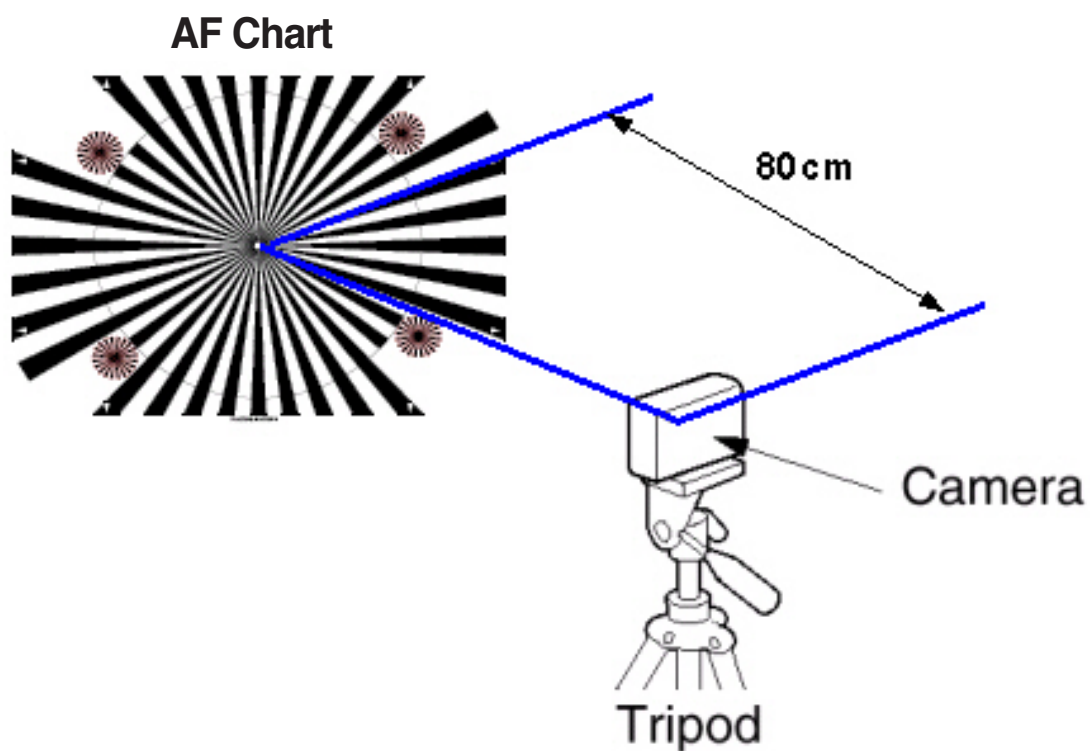

d...Download the program and save it to SD memory card

e...Insert the SD memory card that has the program file and turn on the camera.

f...The adjustment will be done automatically.

g...After completing the upgrade, the camera is turned off automatically.

<Description of TXT file>

When modify the program, use the Memo Pad of Windows and save it as "STS3105ADJ.txt"

Use only section related to each adjustment.

```

////////////////////////////////////
// PROJECT : STS3-105
// PROCESS : PM Batch Test 8
// DATE : 2007.02.15
////////////////////////////////////

//===== #0. adj control
setting

adj_control check_process_id 65535
adj_control set_process_id 65534
adj_control save_e2prom 1
adj_control save_data_file 1
adj_control save_process_pass 1
adj_control batch 1
adj_control osd_delay 0

adj_control signal 100

//===== #1. OB

delay 5
mode program

adj_ob preview_agc 96
adj_ob preview_target_rgb 0 0 0
adj_ob preview_luma_min_max 1500 4000

adj_ob capture_agc 96
adj_ob capture_target_rgb 0 0 0
adj_ob capture_luma_min_max 1500 4000
adj_ob run

//delay 5
//adj_control signal 100

```

### III . ADJUSTMENT

---

```
//===== #2.LSC

//mode program

adj_lens_shading ng_repeat      3
adj_lens_shading lut_load_percent  80
adj_lens_shading before_capture_skip  1
adj_lens_shading luma_min_max      75 120
adj_lens_shading run

//delay 5

//adj_control signal      100

//===== #3.Battery Level

adj_battery base      211 231

adj_battery half_1  176
adj_battery low_1   170
adj_battery empty_1  166
adj_battery lock_1  162
adj_battery start_1  182

adj_battery half_2  176
adj_battery low_2   169
adj_battery empty_2  165
adj_battery lock_2  161
adj_battery start_2  164
adj_battery run

//===== #4.BackLash

//mode program
//adj_backlash adj_count      2
//adj_backlash max_backlash   85
//adj_backlash run

// Backlash --> burning
Delay 10
//adj_control signal 100

//===== #5.Shutter Closing
```



```

zoom close_to_open
mode program

adj_sh_close max_count          20
adj_sh_close open_init_linedelay  40
adj_sh_close open_init_subdelay   0
adj_sh_close open_linedelay_min_max 35 55

adj_sh_close apt_init_linedelay   43
adj_sh_close apt_init_subdelay    0
adj_sh_close apt_linedelay_min_max 40 60

adj_sh_close iris_skip           0
adj_sh_close iris_adjustrange    6

adj_sh_close gain_skip1          0
adj_sh_close gain_skip2          0

adj_sh_close gain_offset         -3
adj_sh_close gain_setlvalue      208
adj_sh_close gain_adjustrange1   15
adj_sh_close gain_adjustrange2   15

adj_sh_close run

//delay 10
//adj_control signal 100

//===== #6.Strobe

Mode program
Ae metering          1
Ae iso               2
Ae evc              6
Ae preview_fnum     1
Ae preview_s_speed  058
Ae preview_gain     050
Ae lock

//Zoom wide
Delay 10

```

### III . ADJUSTMENT

---

```
adj_strobe_intensity param
adj_strobe_intensity stage      PV2
adj_strobe_intensity flash_table_test  0
adj_strobe_intensity level_test_number  2
adj_strobe_intensity pre_table_index   11 0 0 0 0
adj_strobe_intensity Standard_Luma  190 365 375 720 790 1370
adj_strobe_intensity awb_gain        560 695 280 320
adj_strobe_intensity run

//delay 5
//adj_control signal 100

//===== #7.PUNT

zoom close_to_open      // initialize barrel

mode program
coach idle
ae metering  0          // A* related parameter setting
ae iso      0
ae evc      6
ae preview_fnum 1
set wb auto
coach view
//mode program          // idle -> view
delay 25                // A* convergence delay

adj_punt zoomstep      0 10
adj_punt searching_min_short  307 360 411 460 506 548 573 575 573 574 570
adj_punt searching_max_short  411 460 511 558 604 646 673 679 683 688 690
adj_punt searching_min      105 154 203 250 298 338 359 359 355 352 348
adj_punt searching_max      476 564 613 660 708 748 769 769 765 762 758
adj_punt limit_min_short    317 370 421 470 516 558 583 585 583 584 580
adj_punt limit_max_short    401 450 501 548 594 636 663 669 673 678 680
adj_punt limit_min          135 184 233 280 328 368 389 389 385 382 378
adj_punt limit_max          446 534 583 630 678 718 739 739 735 732 728
adj_punt slop_min           -100 -100 -90 -100 -130 -150 -170 -170 -170 -170
adj_punt slop_max           60 80 100 120 140 160 180 180 180 180
adj_punt run

//delay 5
//adj_control signal 100
```

```
//===== #8.Current  
Consumption  
mode program  
delay 20  
zoom wide  
delay 30  
zoom tele  
delay 20  
mode playback  
delay 10  
mode program  
poweroff zoom__close
```

※ SD CARD should be formatted at PC.

### III . ADJUSTMENT

---

#### 11) BURNING TEST

BURNING TEST : After changing the MAIN PCB and parts, check whether all of the camera functions work correctly.

CCD DEFECT CELL : After changing the MAIN PCB and CCD, adjust the DEFECT CELL of CCD.

a...Download program and save it to SD memory card.

b...Insert the SD memory card that has the program file and turn on the camera

c...The function will be done in order automatically

※ After completing the functions, "Burning END" message will display and the camera turn off automatically.

<Description of TXT file>

When modify the program, use the Memo Pad of Windows and save it as "STS3105ADJ.txt"

Use only section related to each adjustment.

```
////////////////////////////////////  
// PROJECT : STS3-105  
// PROCESS : Backlash / Burnin / Defective Pixel  
// DATE : 2007.02.15  
////////////////////////////////////  
  
//===== #0. adj control setting  
  
adj_control check_process_id 65532  
adj_control set_process_id 65528  
adj_control save_e2prom 1  
adj_control save_data_file 1  
adj_control rePeat_CNT 30  
adj_control override_tv_usb 1  
adj_control do_check_process_id 1 //  
  
//===== #1. Backlash  
  
mode program
```

```
adj_backlash adj_count      2
adj_backlash max_backlash  85
//adj_backlash integration
adj_backlash run

delay 20

//===== #2. Burnin Test

adj_burnin delete_all
//adj_burnin format_keep
adj_burnin prog_mode
adj_burnin lcd_on

adj_burnin flash_cap
adj_burnin flash_off_cap
adj_burnin norm_cap
adj_burnin macro_cap

adj_burnin selftimer_cap
adj_burnin play_mode

adj_burnin prog_mode
adj_burnin avi_cap_5sec

adj_burnin easy_mode

adj_burnin aux_led_on
adj_burnin wait_2sec
adj_burnin aux_led_off

adj_burnin burnin_end

//===== #3. CCD Defective Pixel

//start adj_defective_pixel
//adj_control check_process_id 65535
//adj_control save_e2prom 1
//adj_control save_data_file 1
```

### III . ADJUSTMENT

---

```
mode program
//ae metering multi
//ae iso 200
//ae ev 0
//ae iris 0
//awb wbal auto
//coach view
//delay 25

adj_defect integration
adj_defect ref_level_short 800
adj_defect ref_level_long 3500
adj_defect exp_time 6
adj_defect defect_max_num1 30000
adj_defect defect_max_num2 30000
//adj_defect run
//end adj_defect
//delay 10
//poweroff zoom_close
```

※ SD CARD should be formatted at PC.

## 12) CCD DEFECT CELL

After changing the MAIN PCB and CCD, adjust the DEFECT CELL of CCD.

<How to act>

- ① Check the reference level and exposure time setting and do the Defective Pixel  
Do the White Defective Pixel for STS3-63, TH-73R and L2-74.
- ② Do the inspection by referencing the specification (Maxium number of Defective cell)
- ③ Write the number of Defective Cell at the Data file by referencing the information of CARD WRITE.

<How to adjust>

- a...Download program and save it to SD memory card.
- b...Insert the SD memory card that has the program file and turn on the camera.
- c...Adjustment will be done automatically.
- d...After completing the adjustment, the camera is turned off automatically.

<Description of TXT file>

When modify the program, use the Memo Pad of Windows and save it as "STS3105ADJ.txt"  
Use only section related to each adjustment.

```

////////////////////////////////////
// PROJECT : STS3-105
// PROCESS : Backlash / Burnin / Defective Pixel
// DATE : 2007.02.15
////////////////////////////////////

//===== #0. adj control setting
    
```

### III . ADJUSTMENT

---

```
adj_control check_process_id 65532
adj_control set_process_id 65528
adj_control save_e2prom 1
adj_control save_data_file 1
adj_control rePeat_CNT 30
adj_control override_tv_usb 1
adj_control do_check_process_id 1 //

//===== #1. Backlash

mode program

adj_backlash adj_count 2
adj_backlash max_backlash 85
//adj_backlash integration
adj_backlash run

delay 20

//===== #2. Burnin Test

adj_burnin delete_all
//adj_burnin format_keep
adj_burnin prog_mode
adj_burnin lcd_on

adj_burnin flash_cap
adj_burnin flash_off_cap
adj_burnin norm_cap
adj_burnin macro_cap

adj_burnin selftimer_cap
adj_burnin play_mode

adj_burnin prog_mode
adj_burnin avi_cap_5sec

adj_burnin easy_mode

adj_burnin aux_led_on
adj_burnin wait_2sec
adj_burnin aux_led_off
```



```
adj__burnin burnin__end

//===== #3. CCD Defective Pixel

//start adj__defective__pixel
//adj__control check__process__id 65535
//adj__control save__e2prom 1
//adj__control save__data__file 1

mode program
//ae metering multi
//ae iso 200
//ae ev 0
//ae iris 0
//awb wbal auto
//coach view
//delay 25

adj__defect integration
adj__defect ref__level__short 800
adj__defect ref__level__long 3500
adj__defect exp__time 6
adj__defect defect__max__num1 30000
adj__defect defect__max__num2 30000
//adj__defect run
//end adj__defect
//delay 10
//poweroff zoom__close
```

※ SD CARD should be formatted at PC.

#### 13) EEPROM READ

To read the data of EEPROM, refer to the below codes.

<How to read>

- a...Insert the codes and save the program in the SD card.
- b...Insert the SD memory card that has the program file and turn on the camera.
- c...Turn on the camera and the DATA in the EEPROM will be copied in the SD card.
- d...Turn off the camera after reading and saving the data.
- e...If you read the SD card in your PC, you can find the file and you can check the EEPROM DATA.

## 12) EEPROM WRITE

If you want to write the DATA of EEPROM, do as follows.

<How to write>

- a...Insert the codes and save the program in the SD card.
- b...Insert the SD card to the camera and turn on the camera.
- c...Turn on the camera and the data of EEPROM will be copied to the camera.
- d...When the copy is complete, the camera is turned off automatically.

# IV. PATTERN DIAGRAM

---

## 1. PARTS ARRANGEMENT FOR EACH PCB ASS'Y

1) MAIN\_TOP

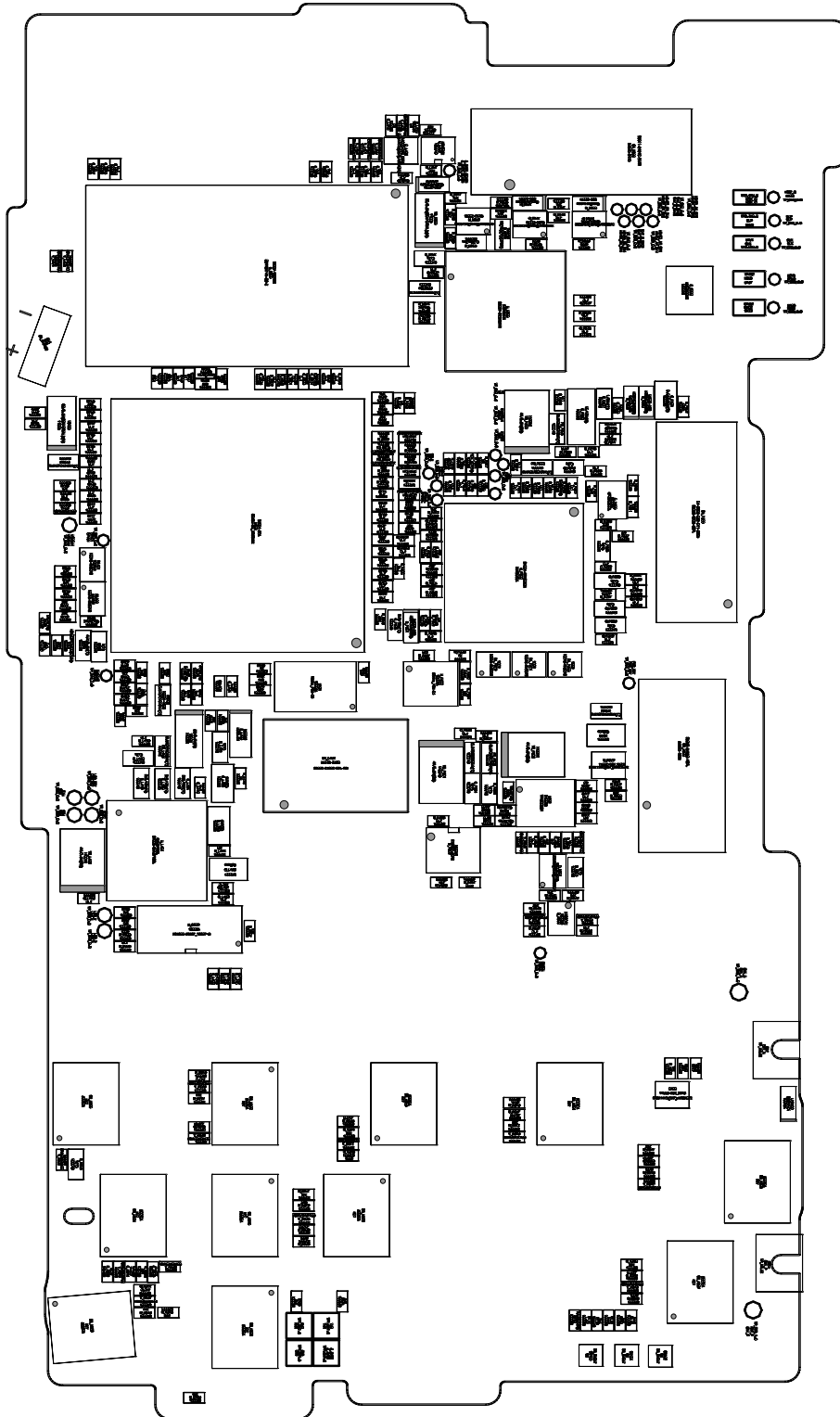

2) MAIN\_BOTTOM

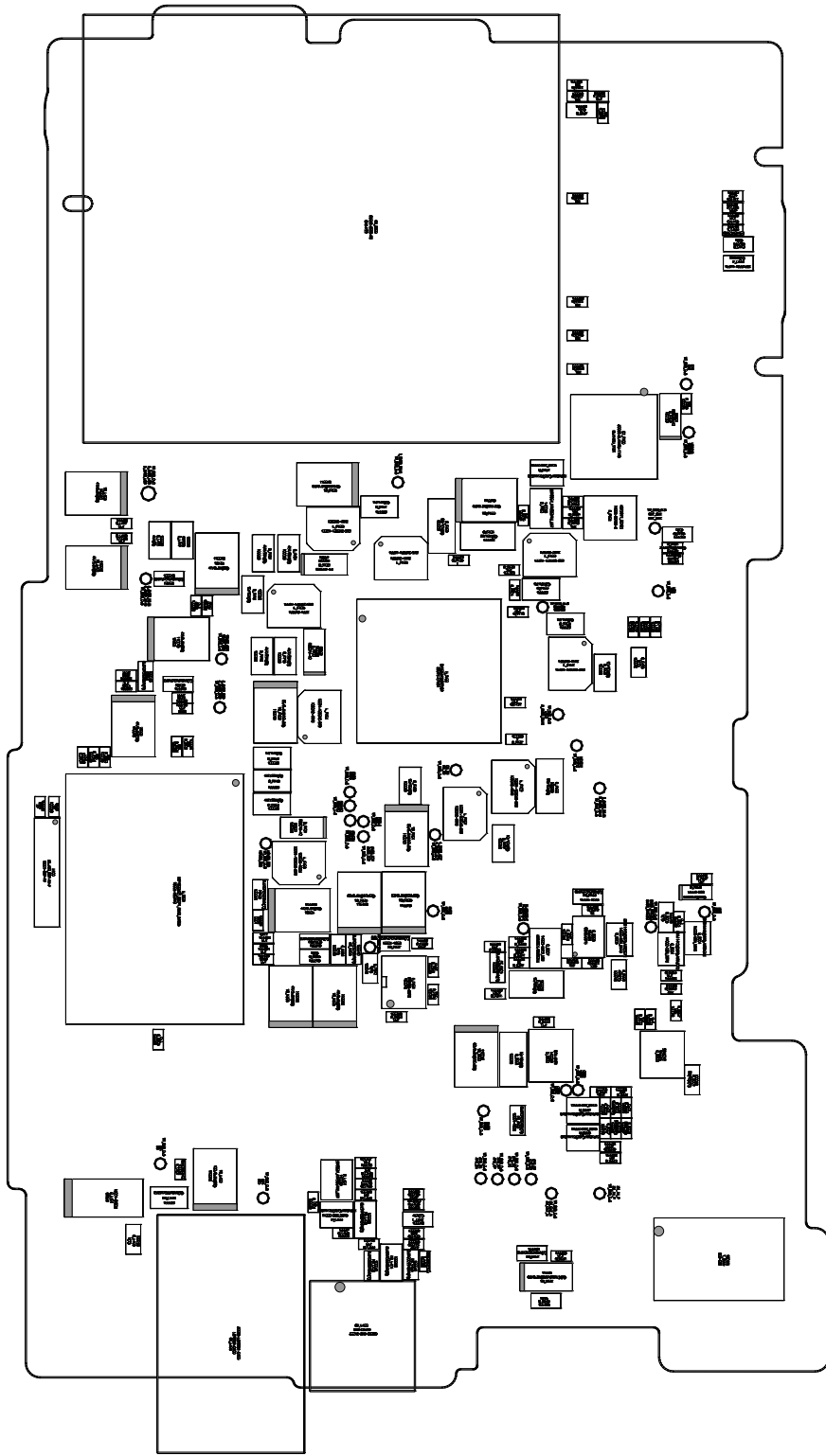

IV. PATTERN DIAGRAM

---

3) CCD

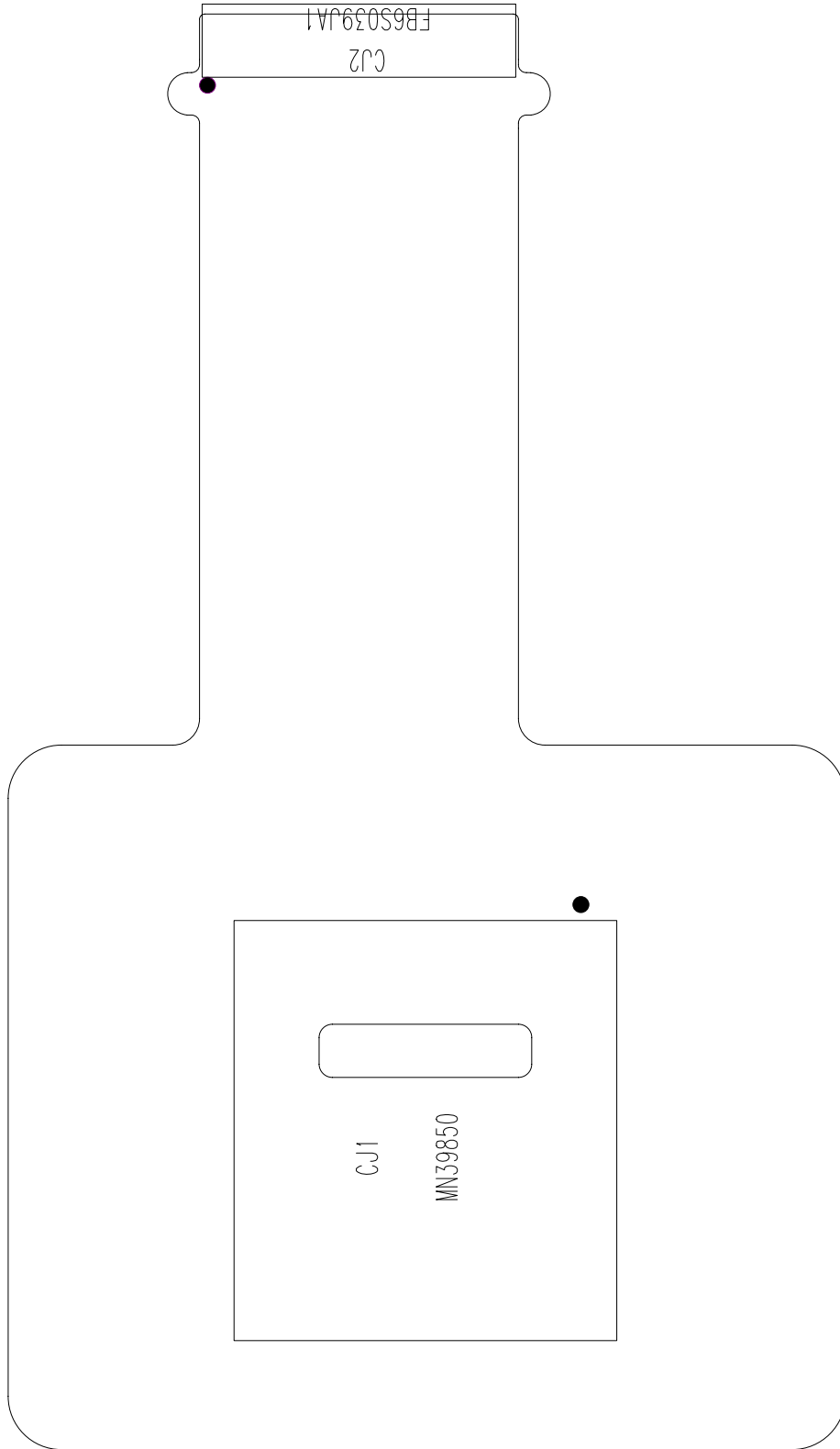

4) MODE

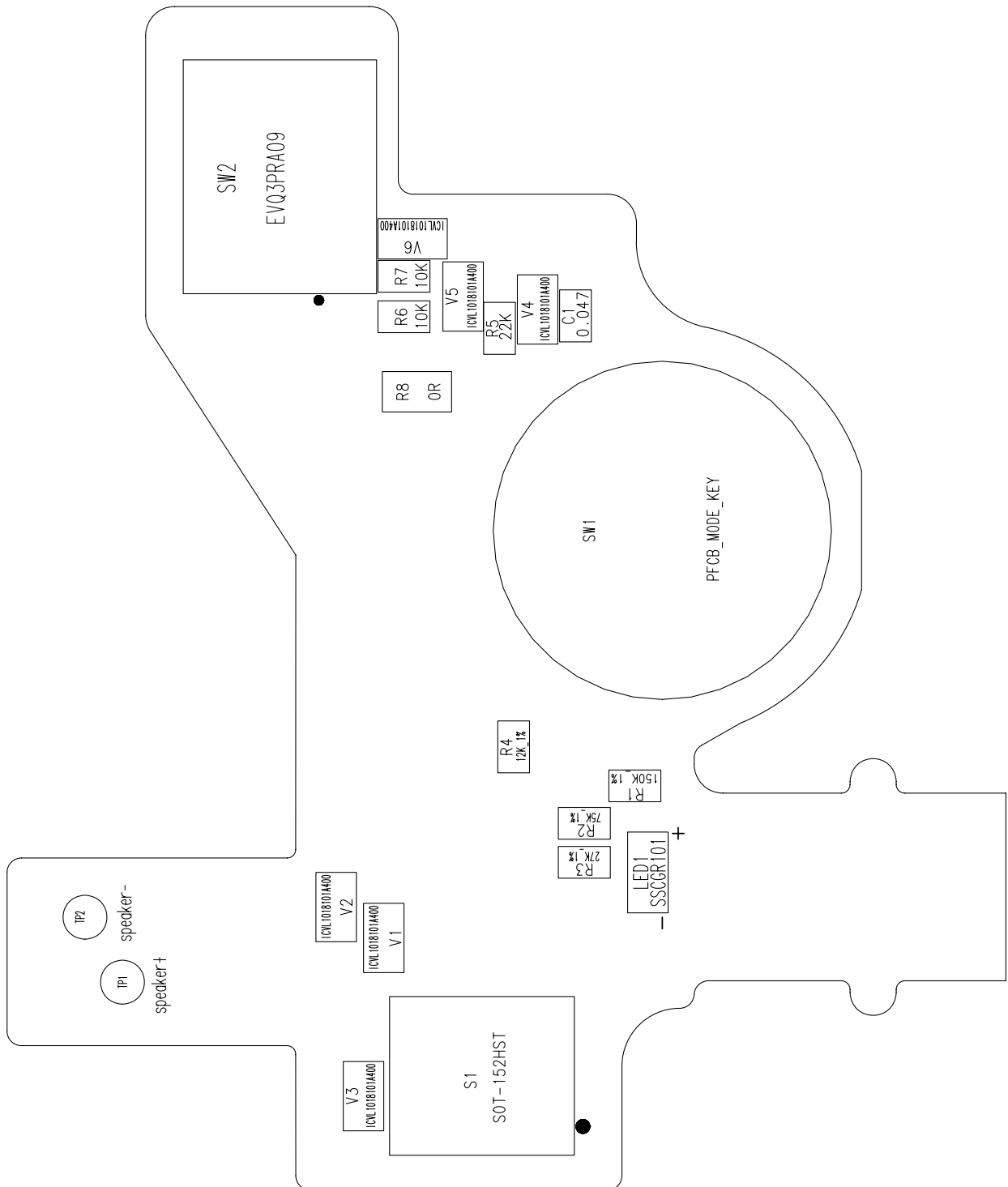

#### IV. PATTERN DIAGRAM

---

##### 5) STROBO

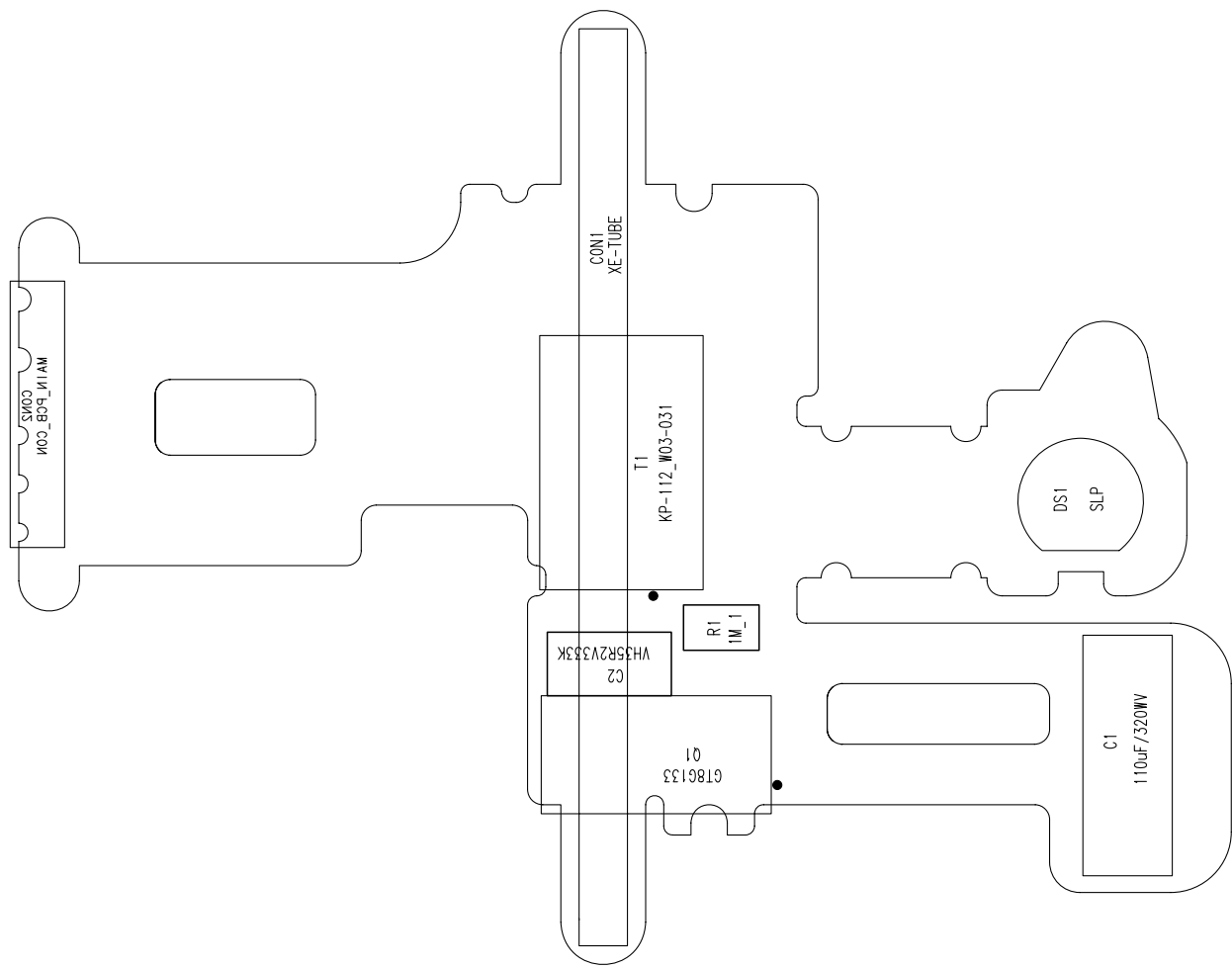



# V. CIRCUIT DIAGRAM

## 1) MAIN

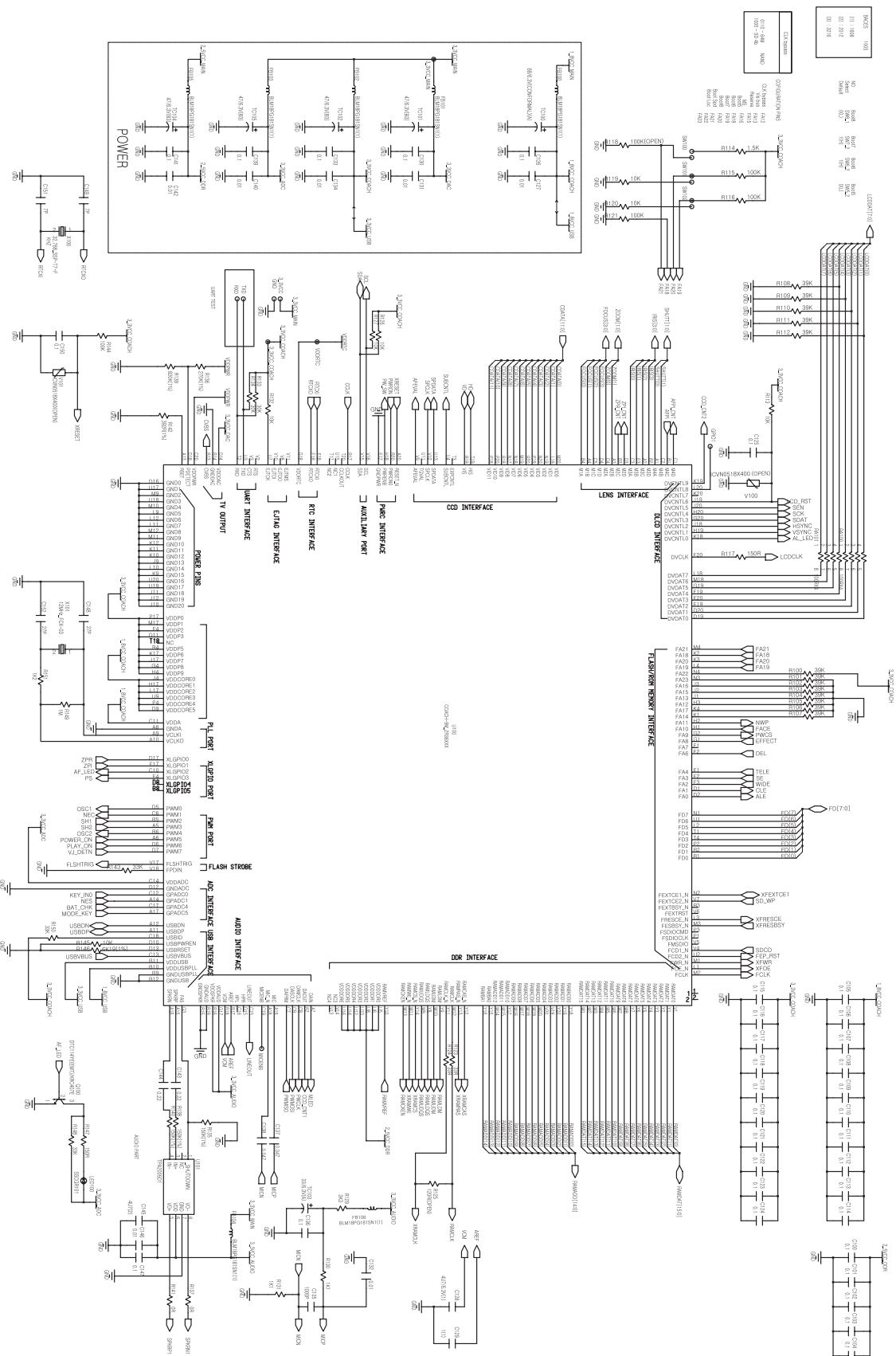

# V. CIRCUIT DIAGRAM

## 2) MAIN\_DDR

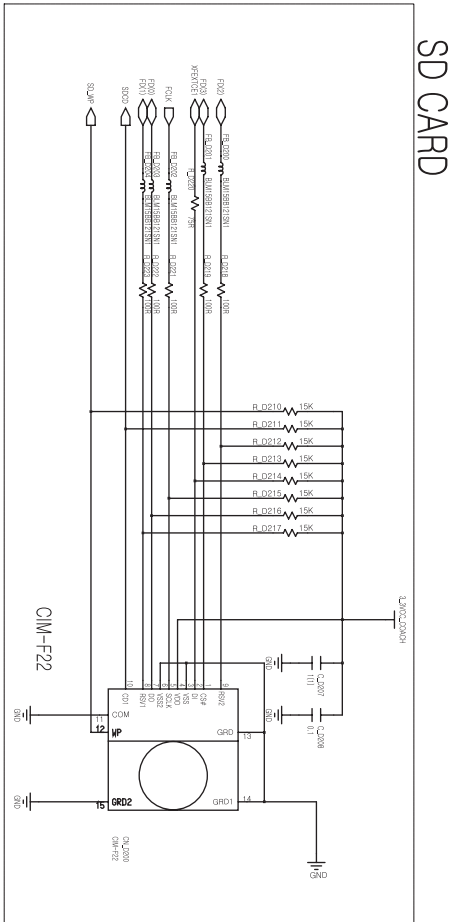
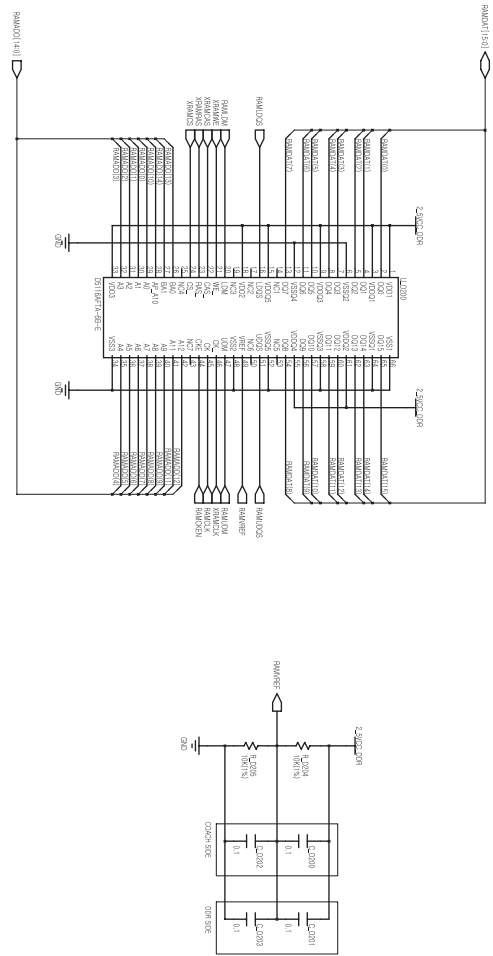
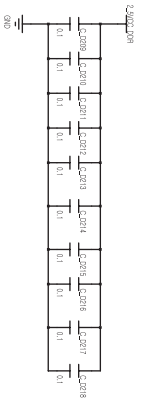
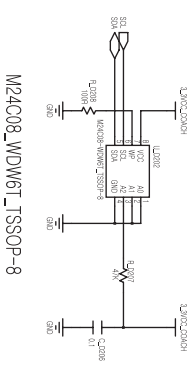
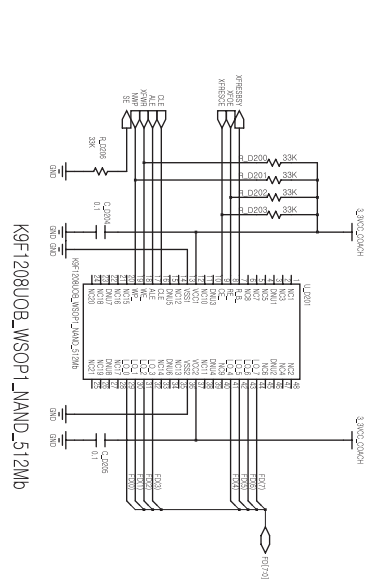

3) MAIN\_CCD(FEP)

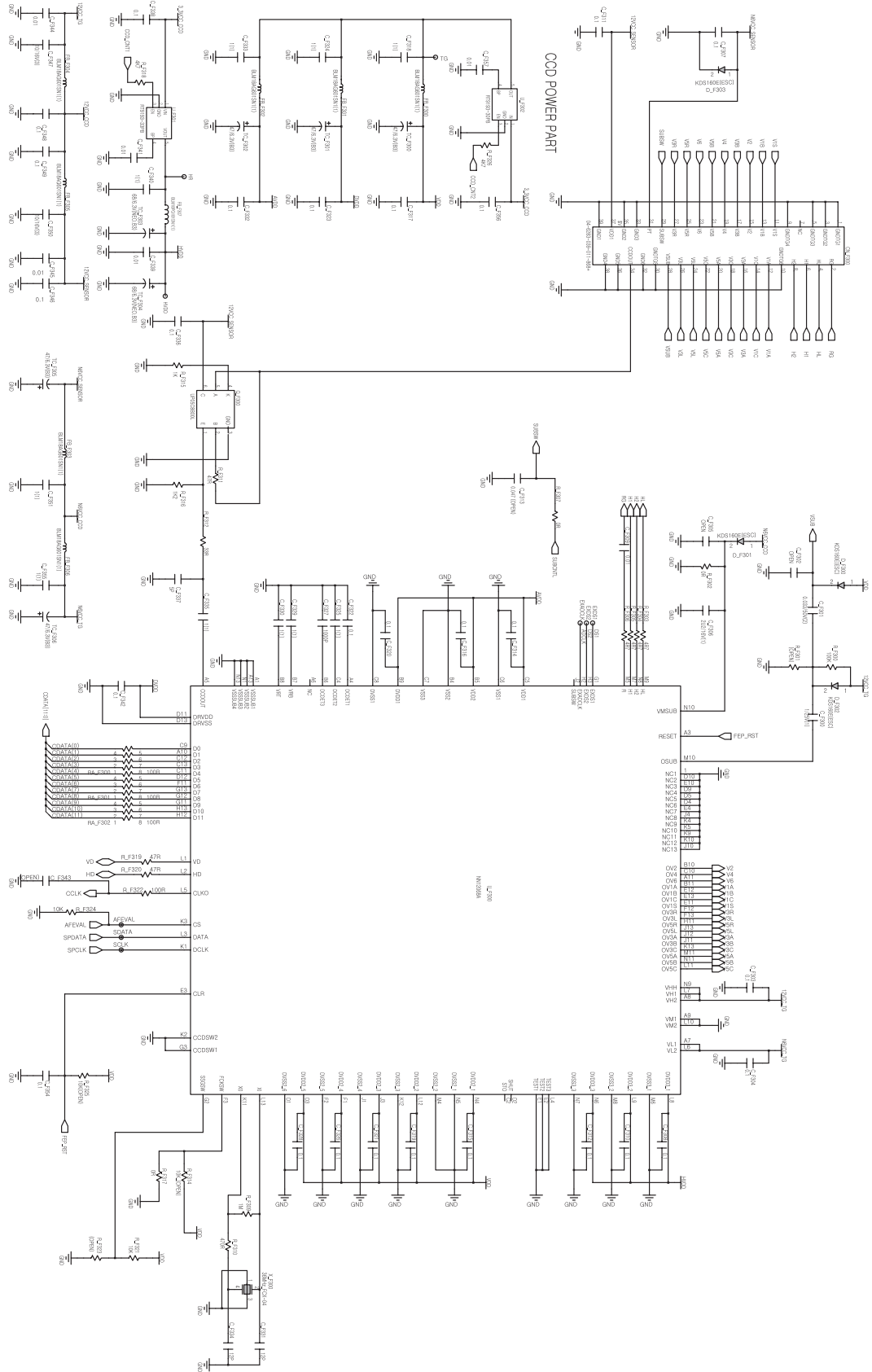

# V. CIRCUIT DIAGRAM

## 4) MAIN\_I/O LCD

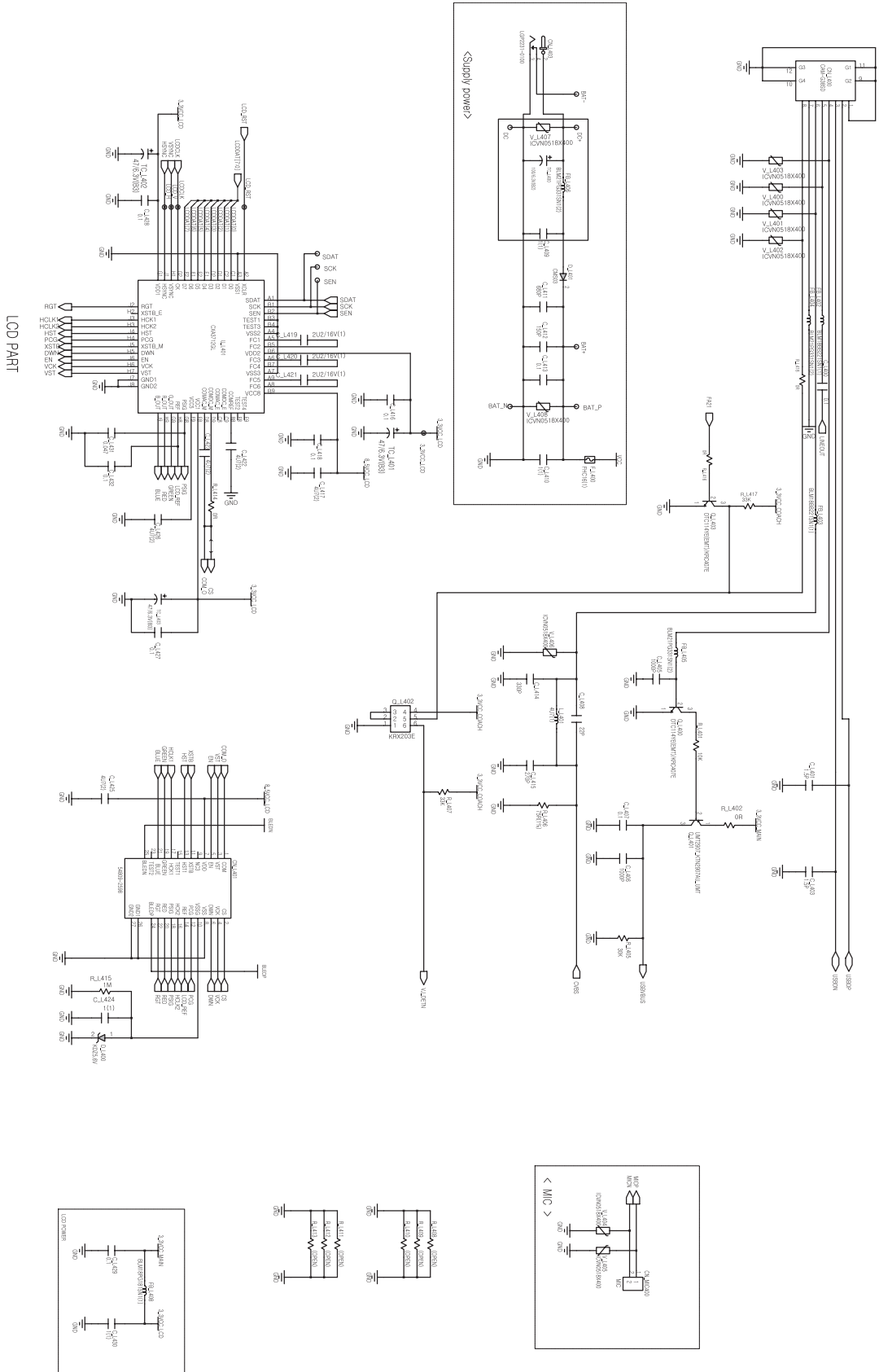

5) MAIN\_KEY

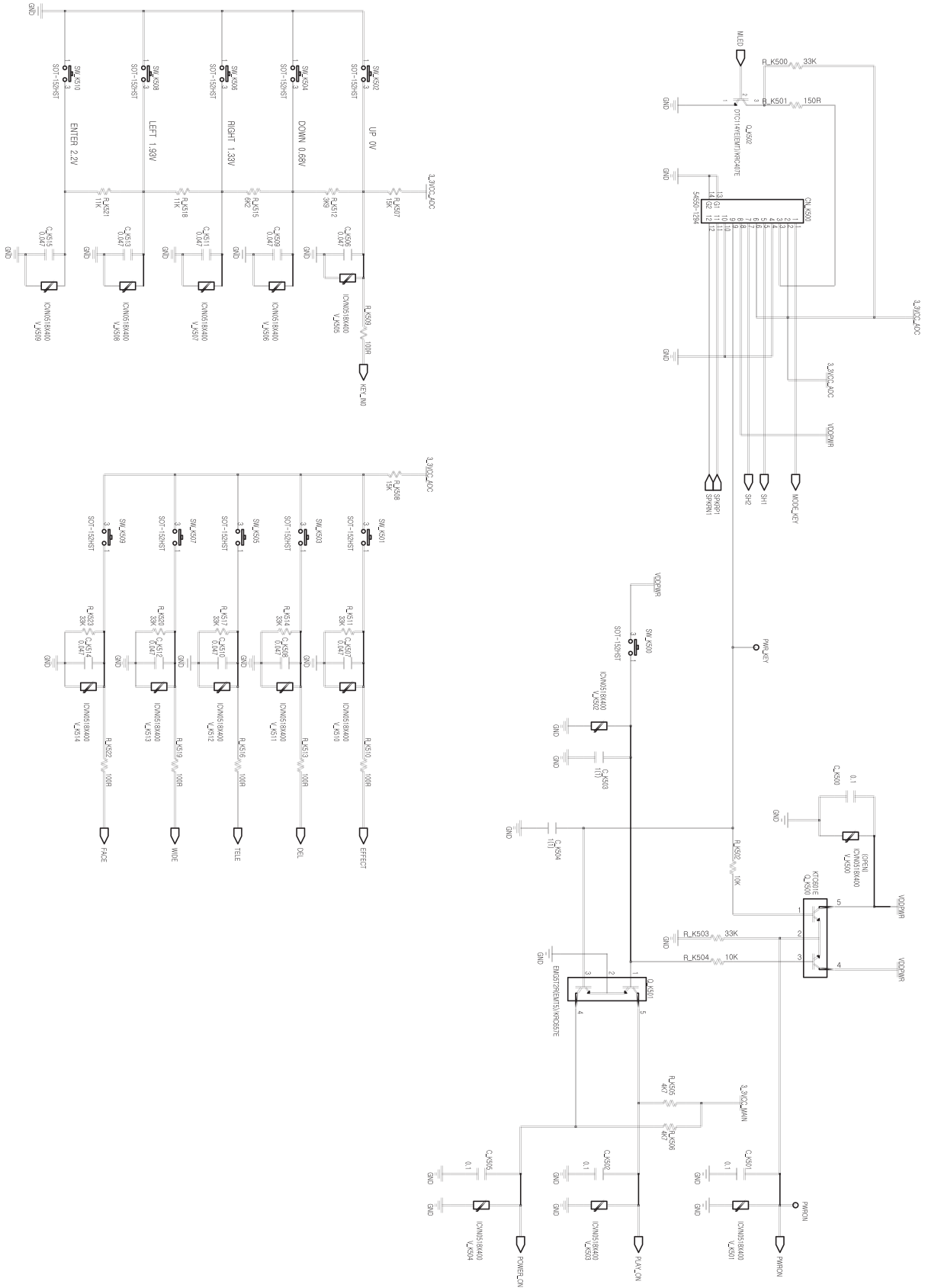

# V. CIRCUIT DIAGRAM

## 6) MAIN\_LENS(MOTOR)

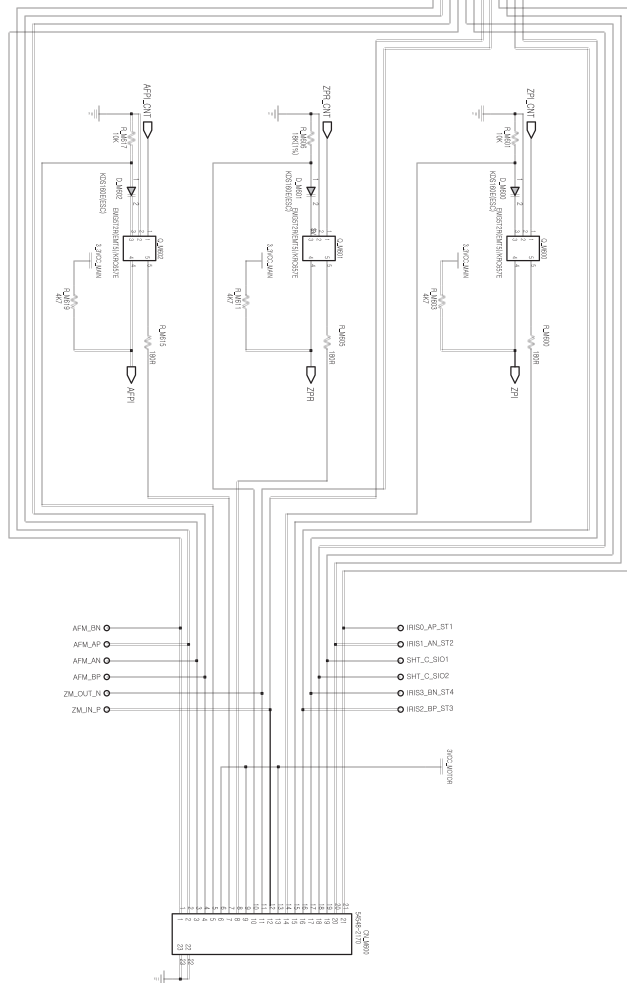
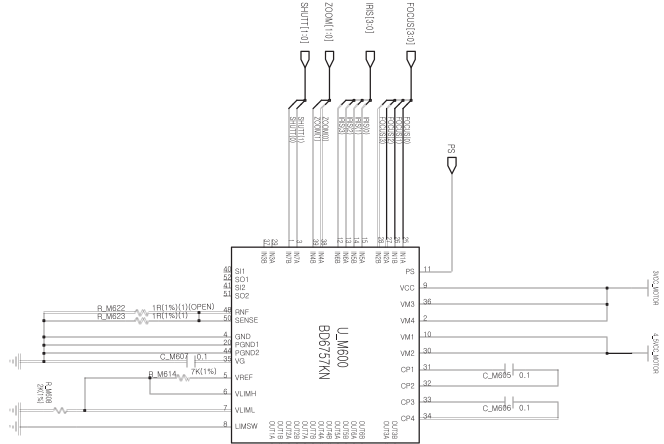
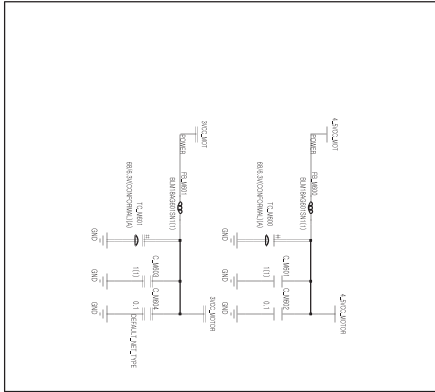



# V. CIRCUIT DIAGRAM

## 8) MAIN\_STROBO

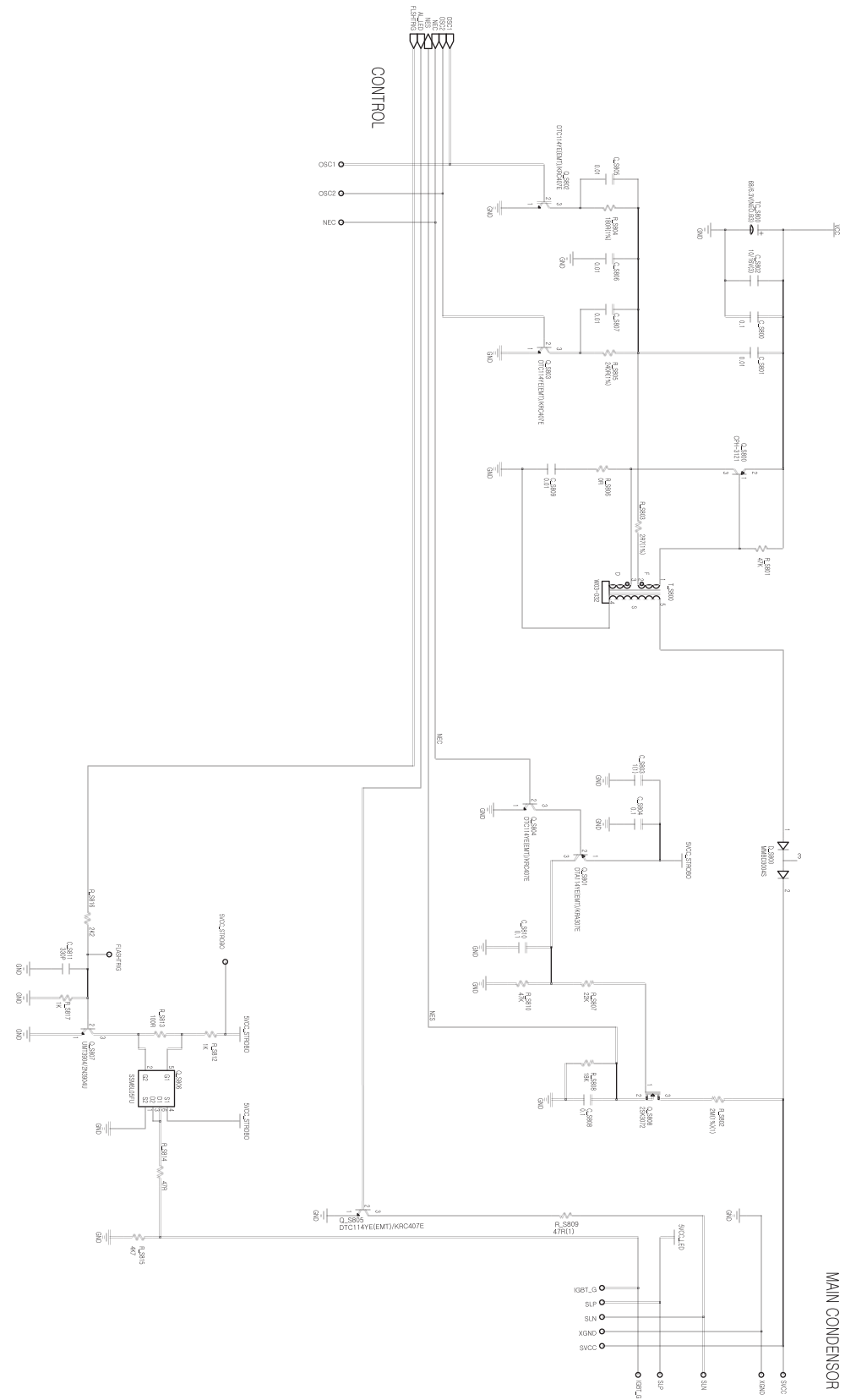



9) CCD

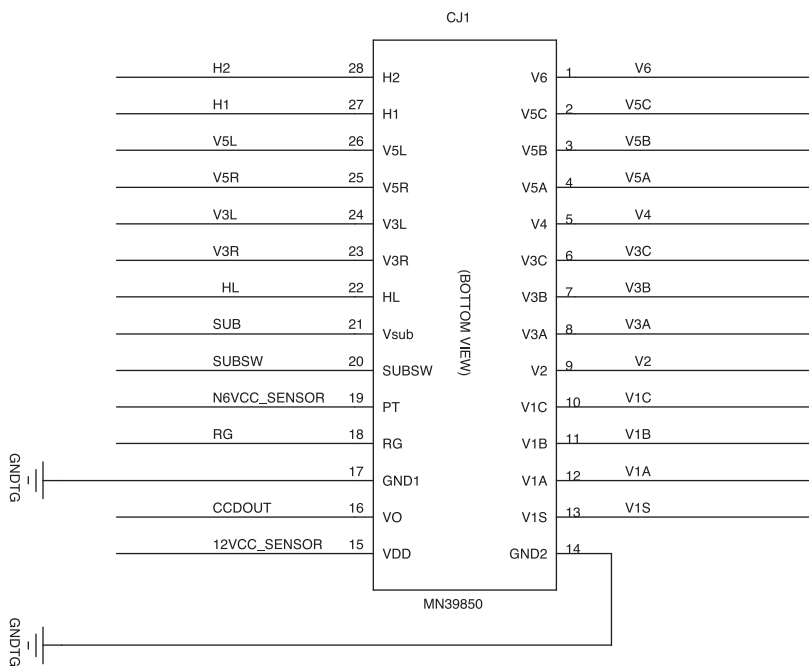
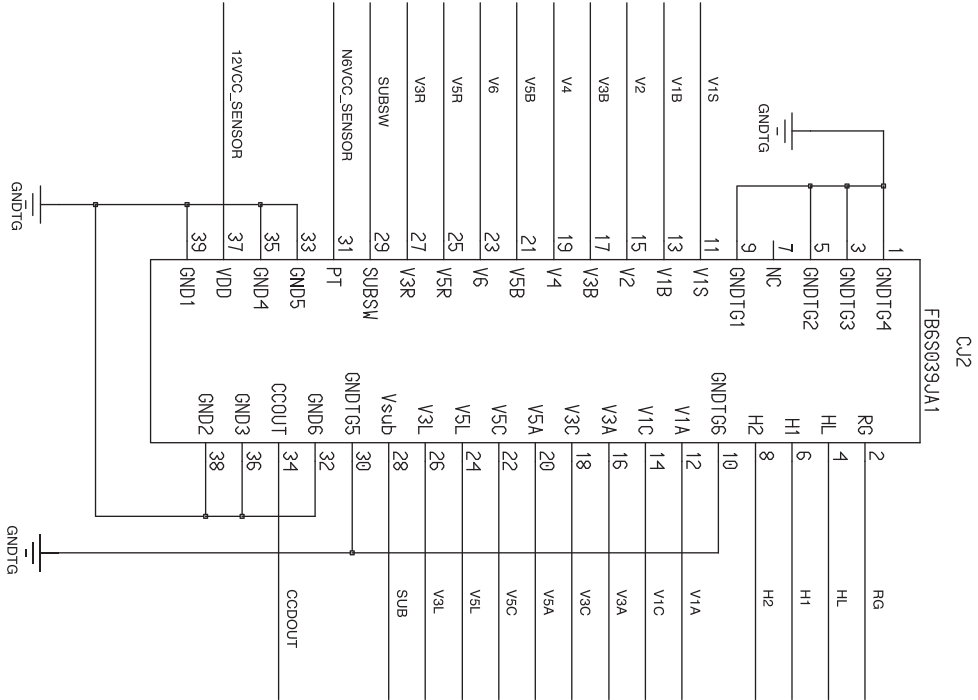

# V. CIRCUIT DIAGRAM

## 10) MODE

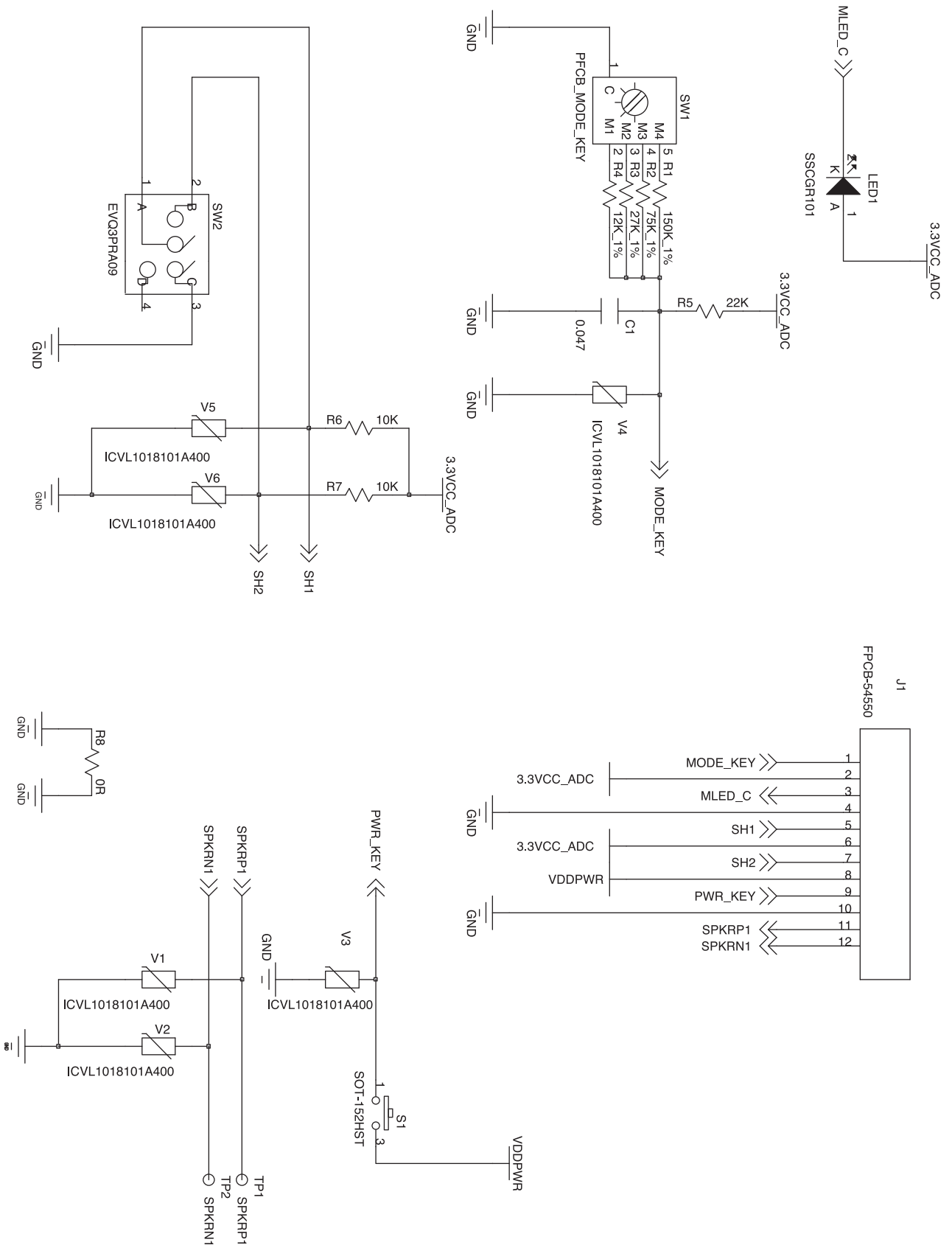

11) STROBO

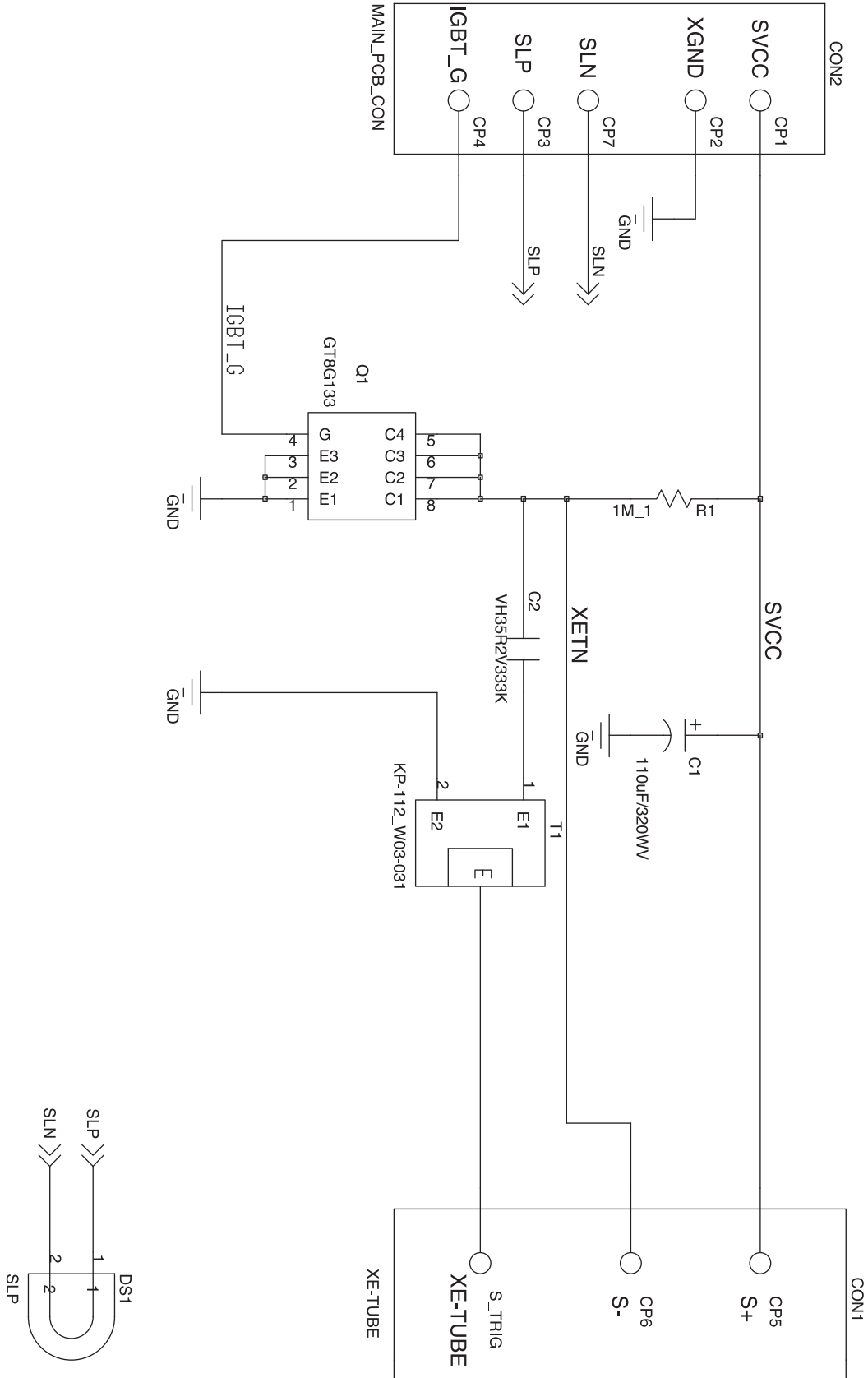

## VI. SERVICE INFORMATION

---

### 1. The order of disassembly and assembly

#### ■ Caution

1. Do the disassembling and assembling camera where the blocking static electricity mat is on the table.
2. When handling the major PCBs of camera, please wearing the band which cuts off the electric current on the wrist.
3. When handling the major parts, be careful of below caution.

Parts	Caution
F PCB type	When assembling the F PCB to the CONNECTOR by using pincette, be careful of tearing and hooking.
CCD & IR CUT	Be careful of the handprinting while handling them. Using the pincette which has soft tip. The spot will be shown by using normal alcohol when cleaning them. Do the repairing where is no dust.
PCB type	Wearing the band which cuts off the electric current and do the repairing where the blocking static electricity mat is on by preventing the defect of parts.
CONTACT type	Be careful of defect and change by pincette.

■ Disassembly

1. Remove 2 screws



2. Remove 2 screws



3. Remove 4 screws



## VI. SERVICE INFORMATION

---

4. Disassemble the BACK COVER.



5. Remove 3 screws.

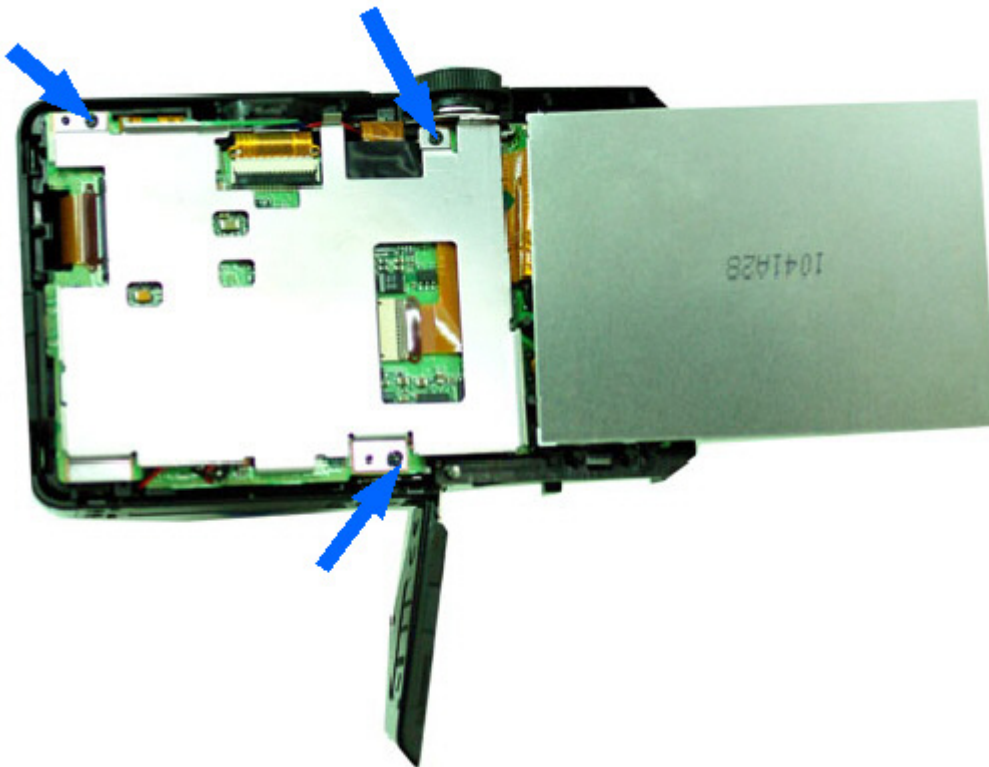

6. Remove 1 screws.

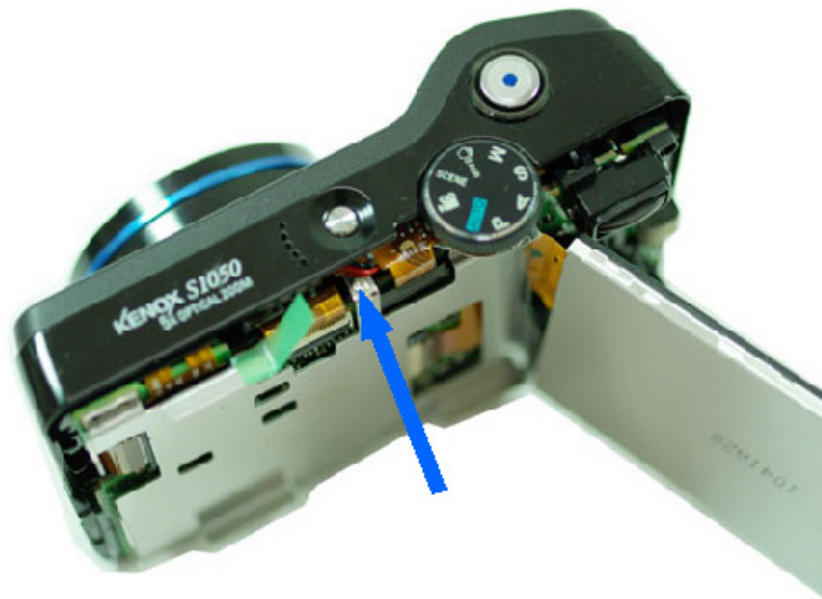

7. Disassemble the LCD panel

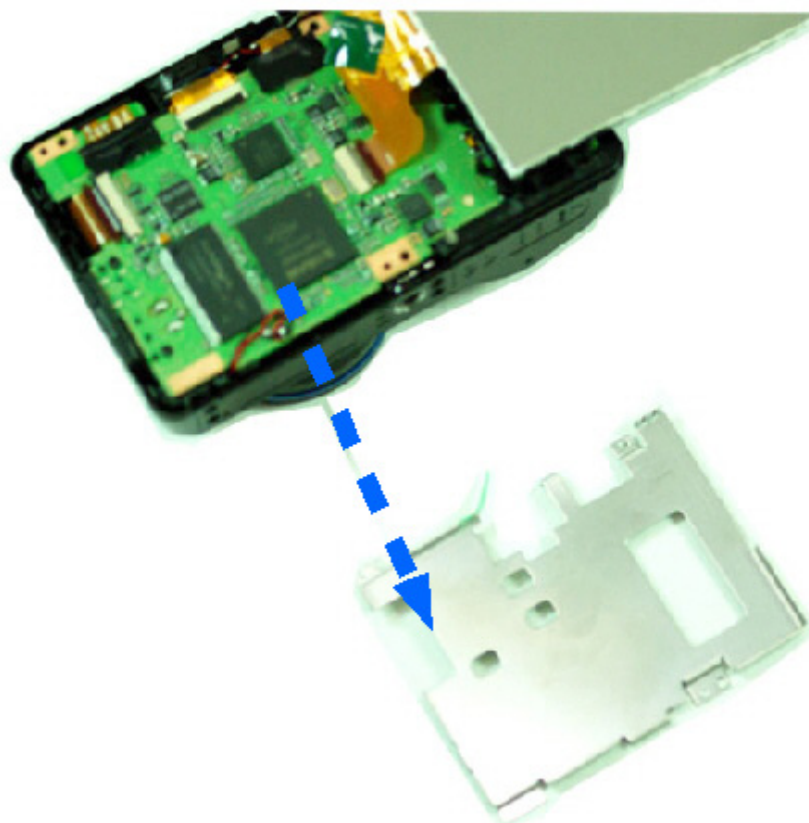

## VI. SERVICE INFORMATION

---

8. Disconnect the PCB from the connector.



9. Disassemble the LCD ASSY.





10. Disassemble the BOTTOM COVER.

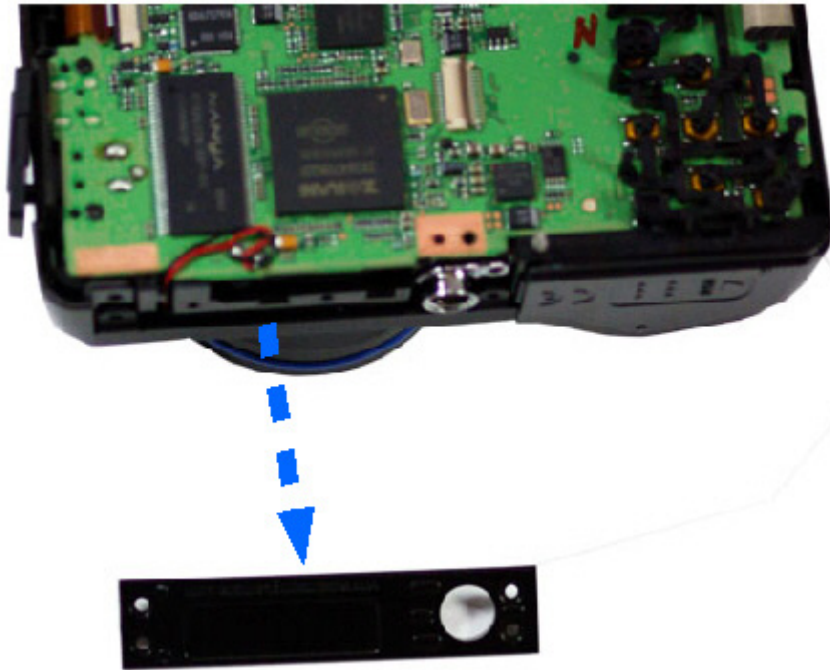

11. Disconnect the PCB from the connector.

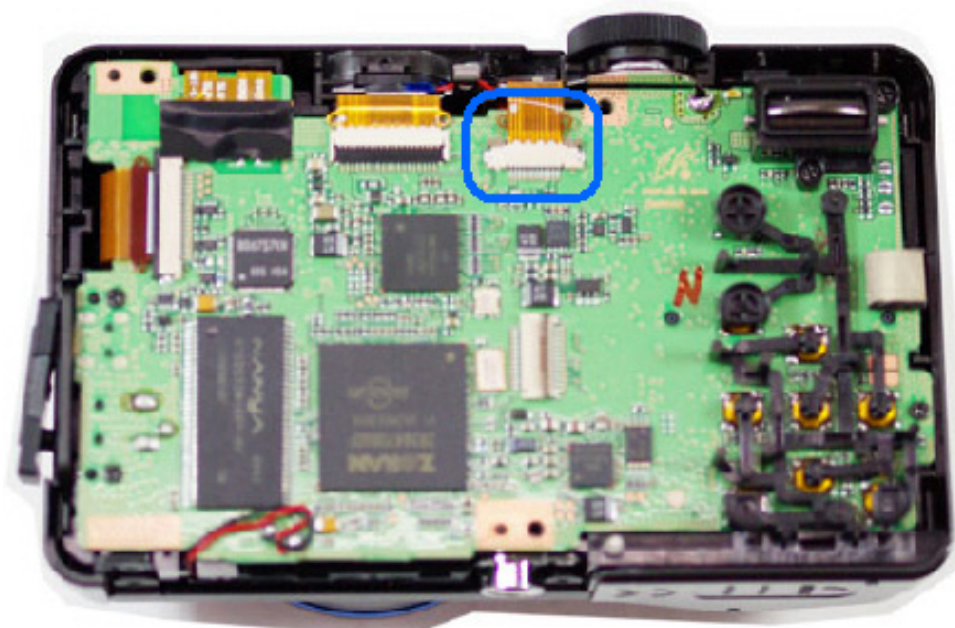

12. Disassemble the FRONT COVER.

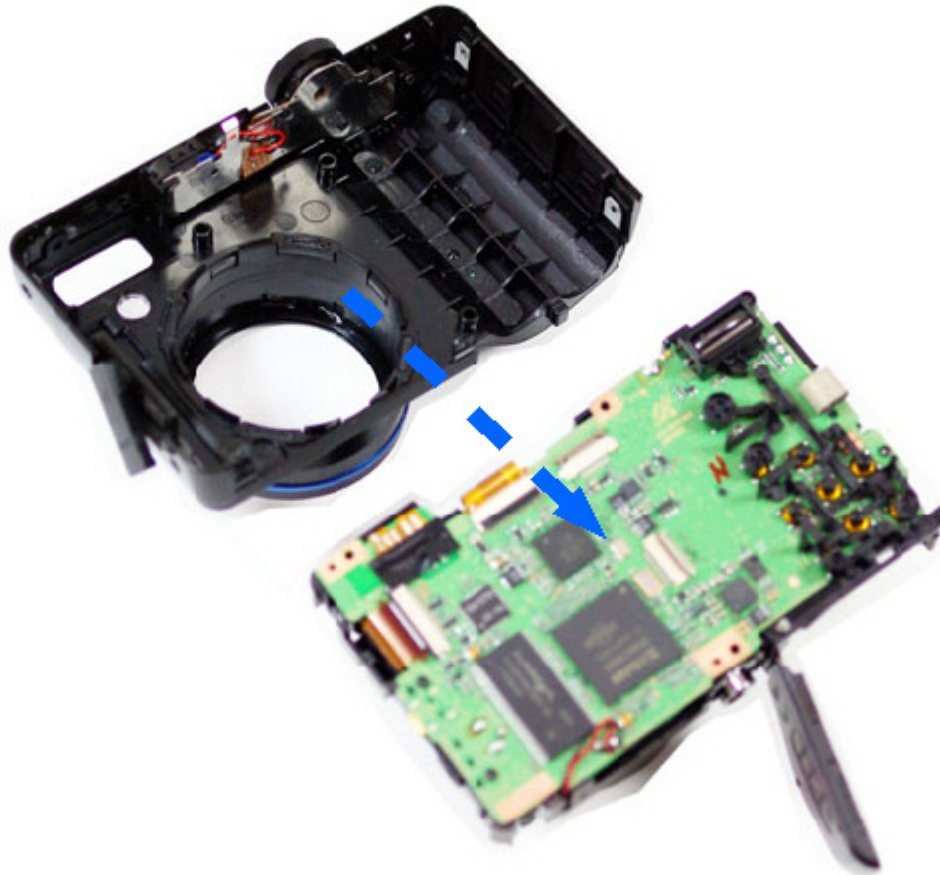

13. **Caution. Discharging point** : Before removing the PCB soldering, discharge the main condenser.

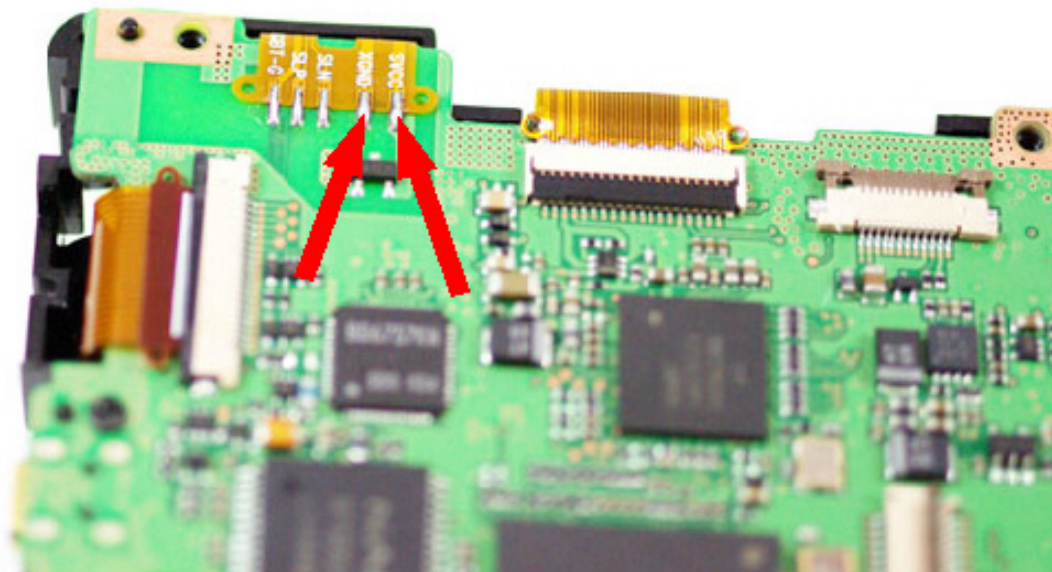

14. Remove 2 screws.

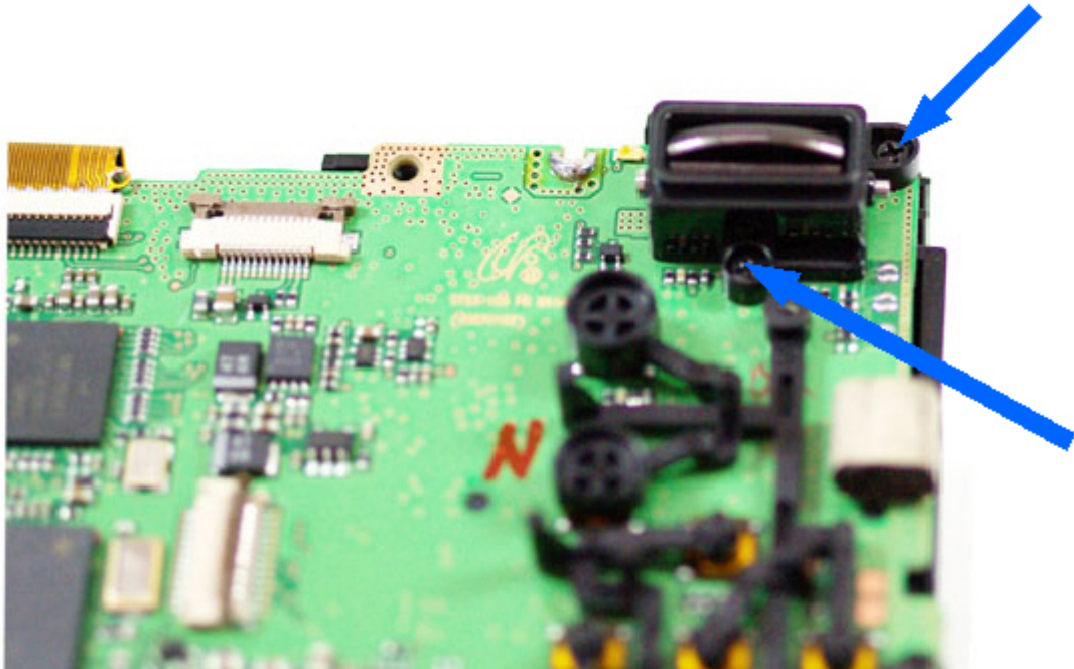

15. Remove the 2 soldering of battery contact and disconnect the Strobe F PCB.  
Remove wire of mic.

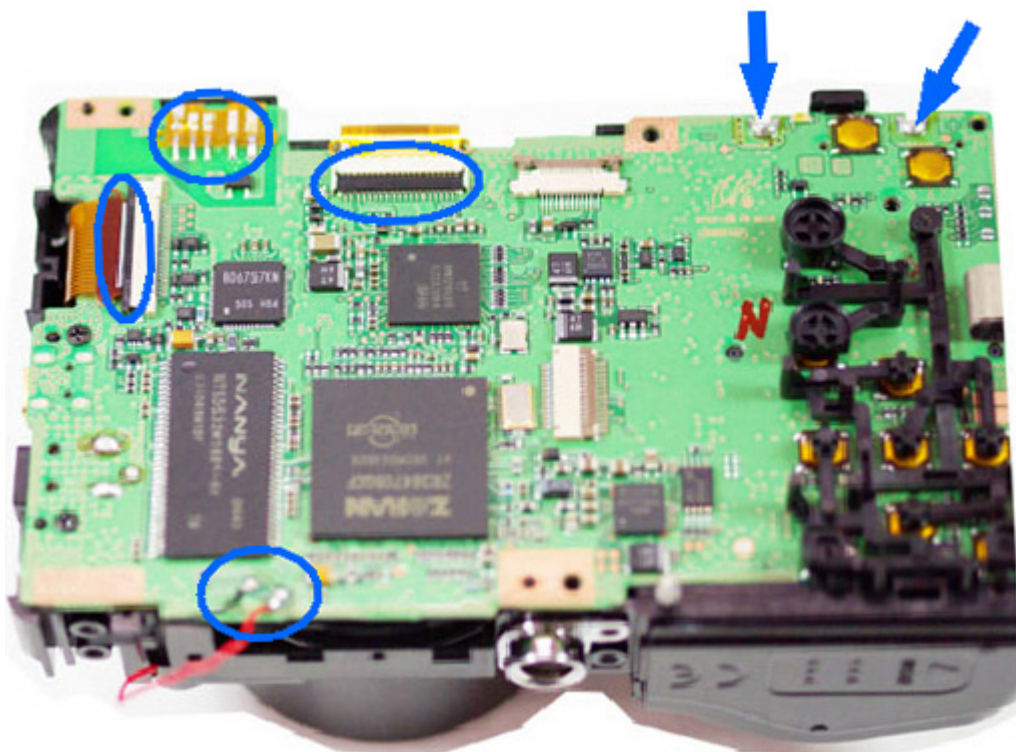

## VI. SERVICE INFORMATION

---

16. Remove 2 screws.

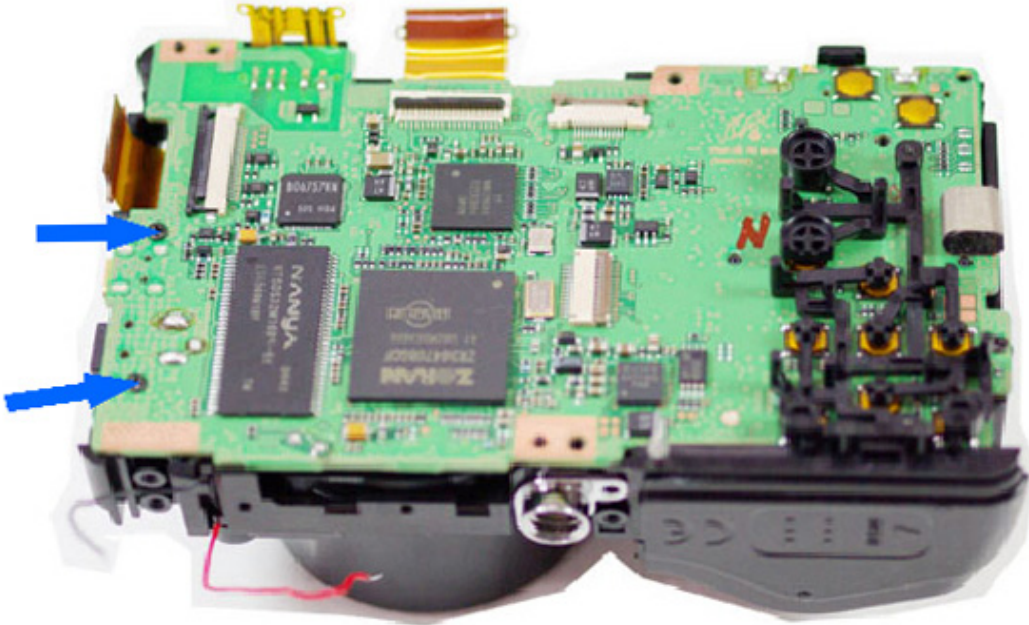

17. Disassemble the MAIN PCB.

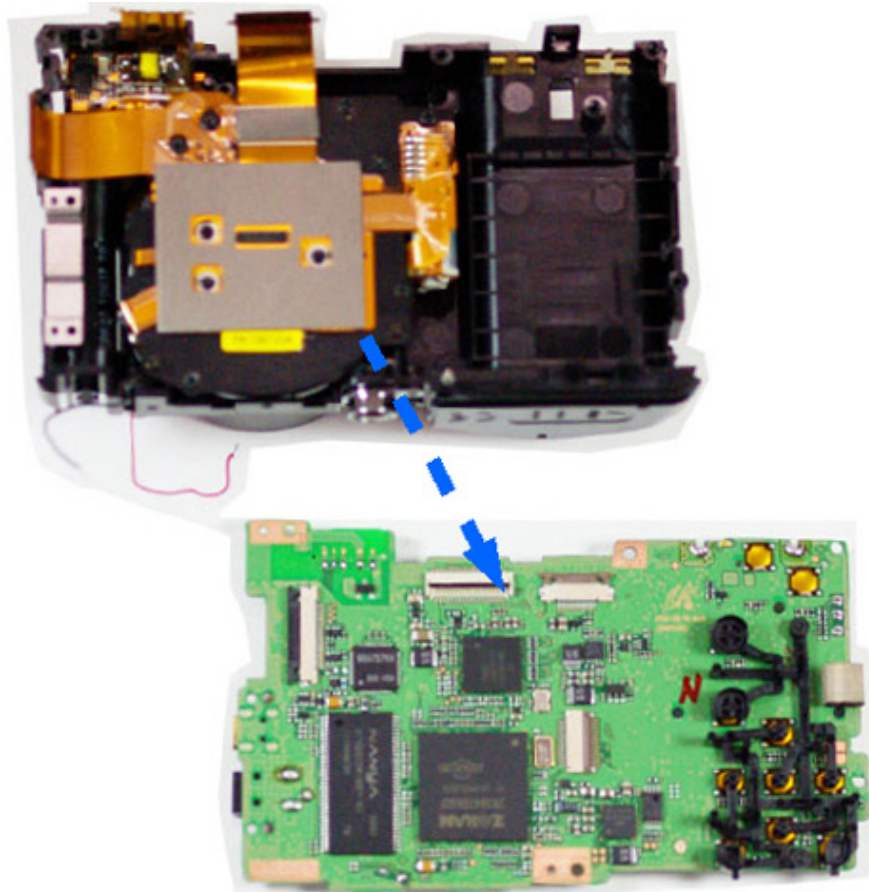

※ Be careful not to lost this.

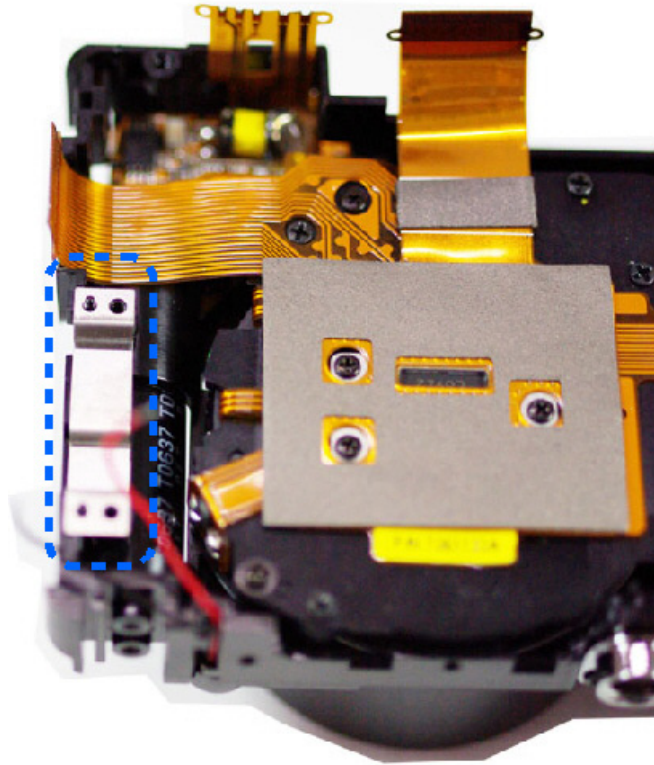

18. Remove 2 screws.



## VI. SERVICE INFORMATION

---

※ Be careful of location of PCB while assembling.

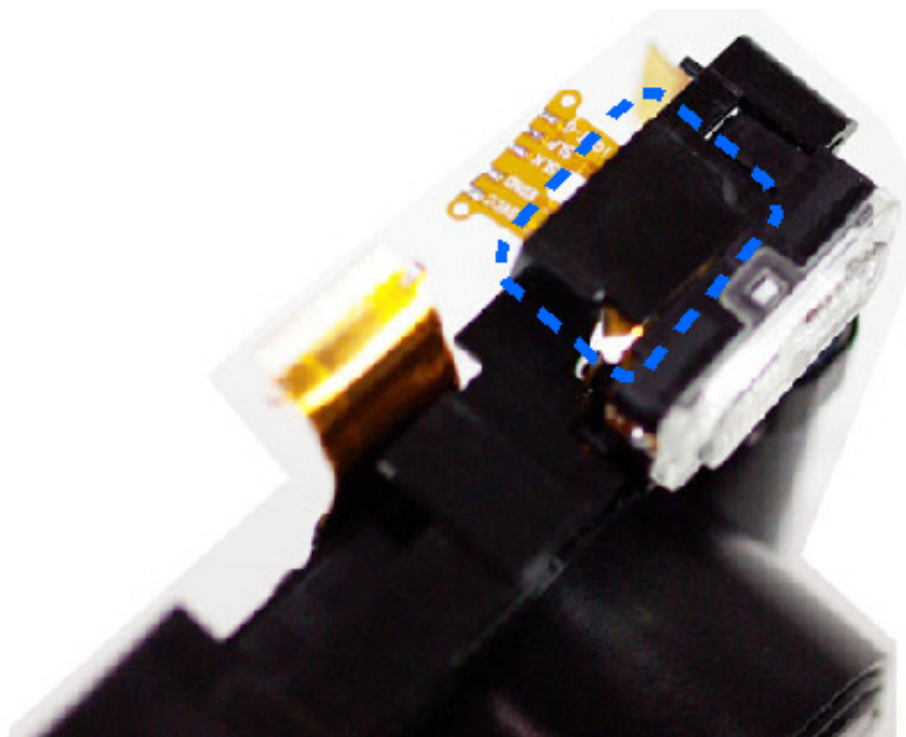

19. Disassemble the STROBE PCB.

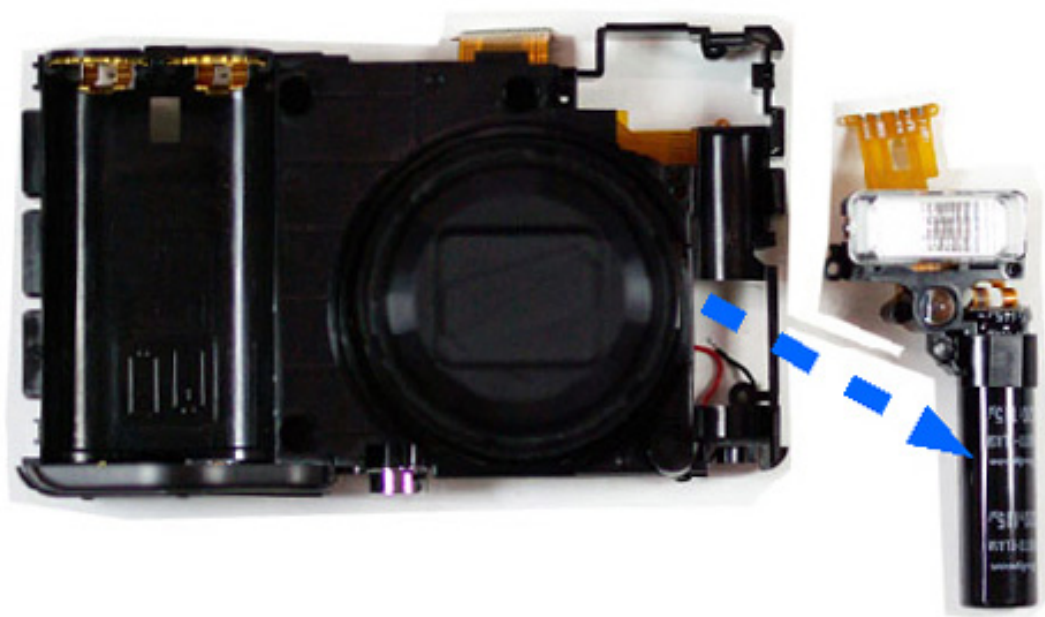

20. Remove 3 screws.

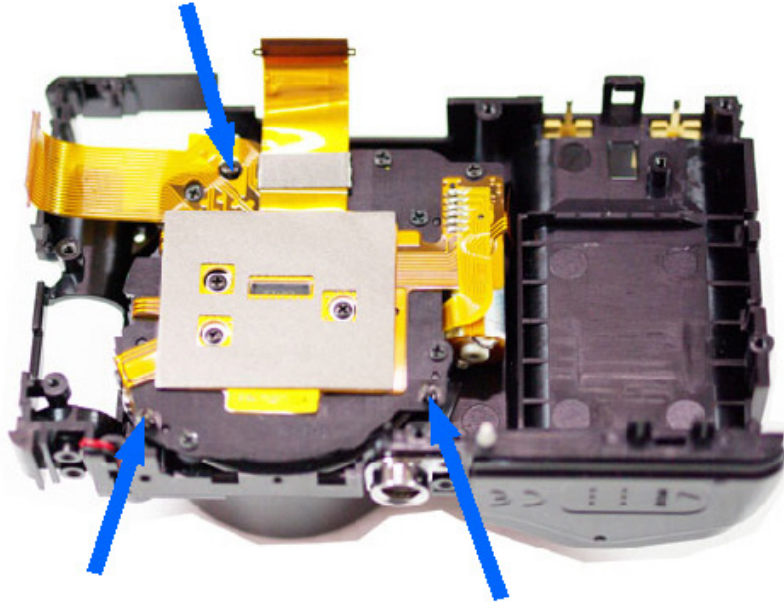

21. Disassemble the Barrel ASSY

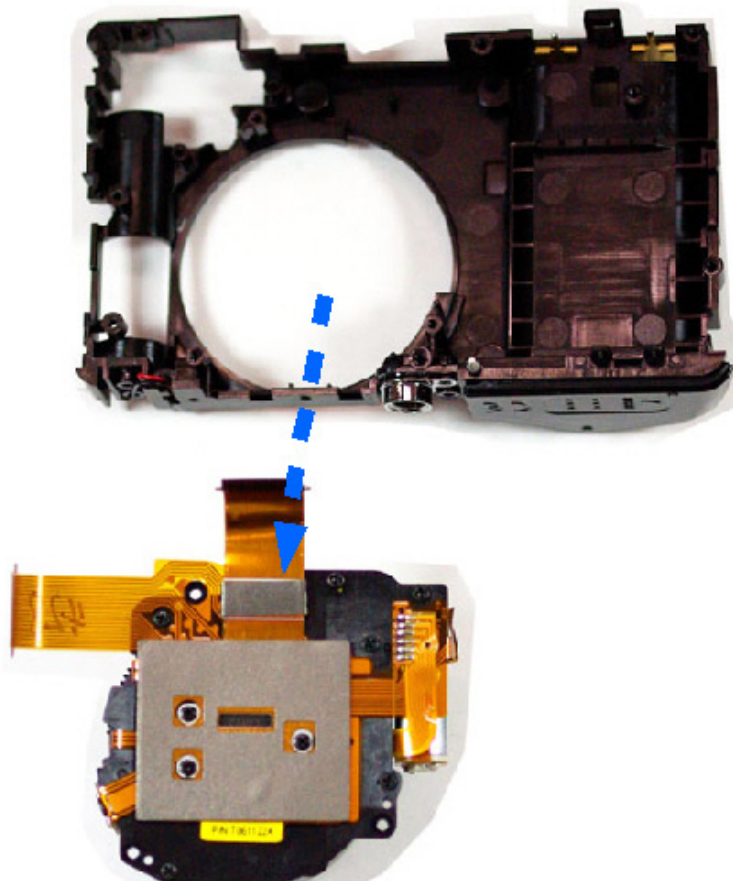

## VI. SERVICE INFORMATION

---

22. Remove 3 screws.

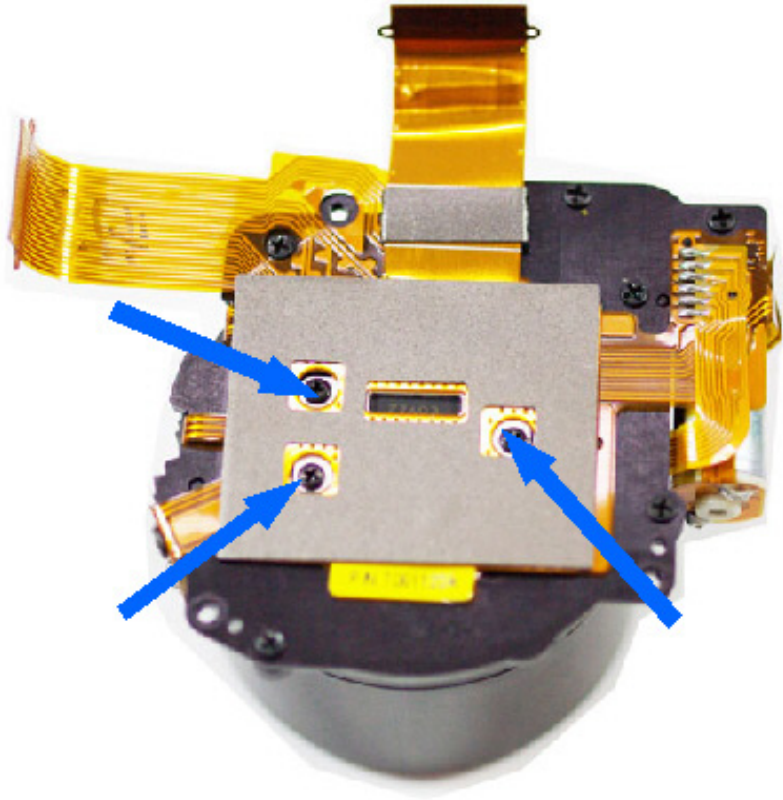

23. Disassemble the CCD.

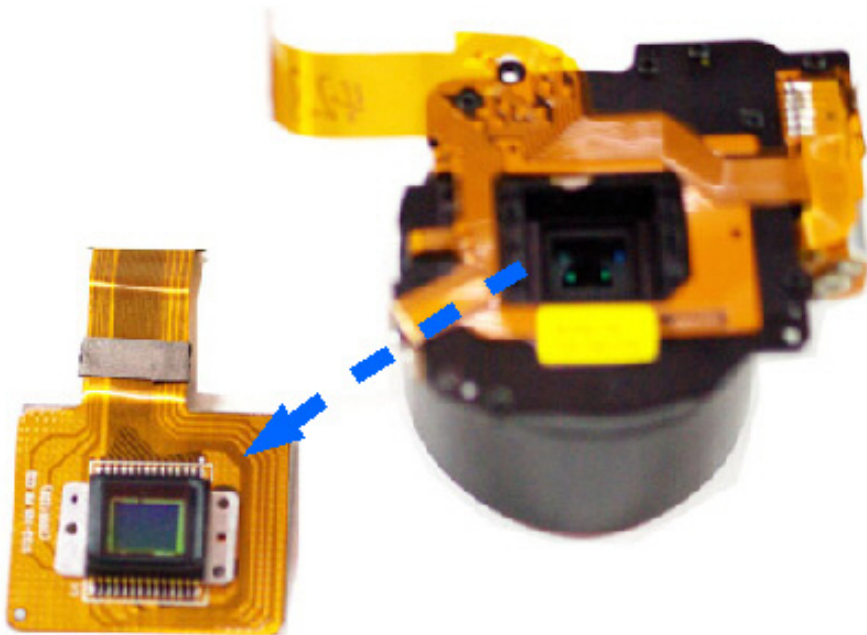



## ■ Disassemble Barrel

1. Remove soldering.

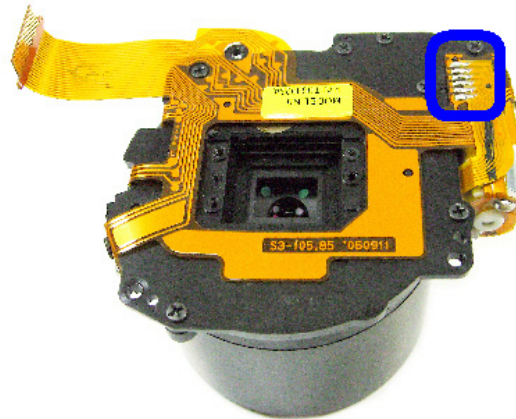

2. Remove 3 screws.

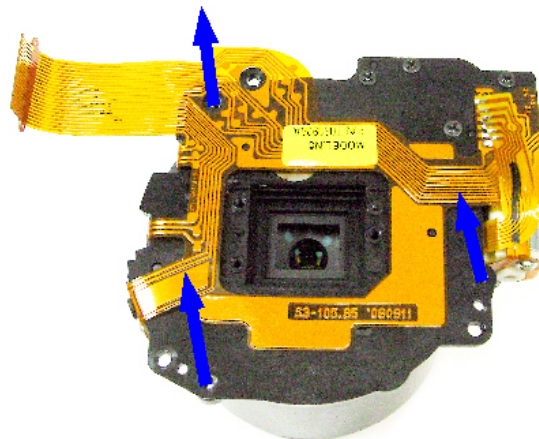

3. After disassembling the Lens base.

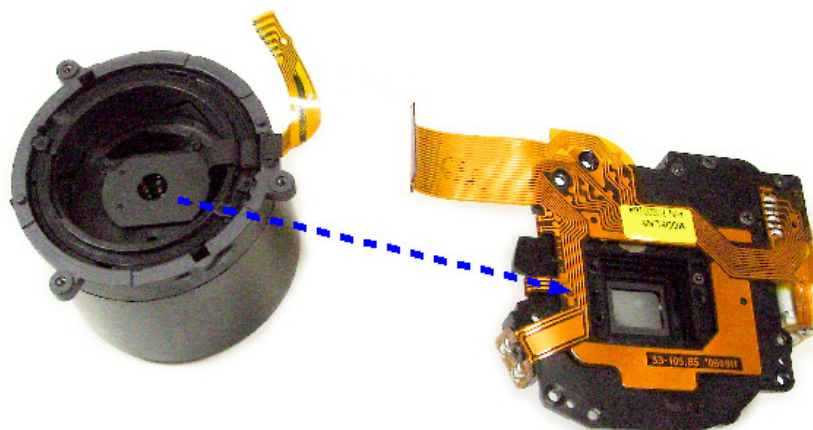

4. Disassemble the Outer Outer Guide Barrel.



5. Move the the Tele posion lie below.



## VI. SERVICE INFORMATION

---

6. Disassemble the Shutter PCB.

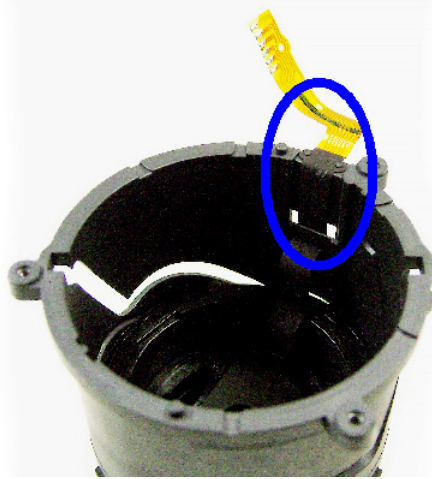



7. Move to the Wide position like below.



## VI. SERVICE INFORMATION

---

8. Disassemble the Cam Barrel.



9. Disassemble the INNER CAM BARREL ASSY.

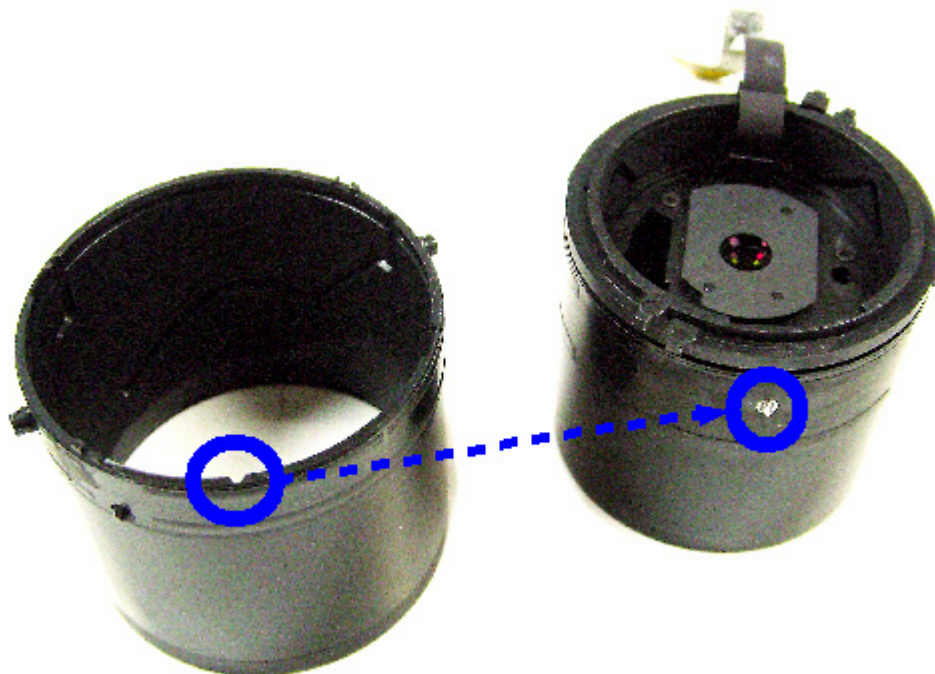

## VI. SERVICE INFORMATION

---

10. Disassemble the Zoom Ring Assy and be careful of position of ZOOM RING ASSY's pin.





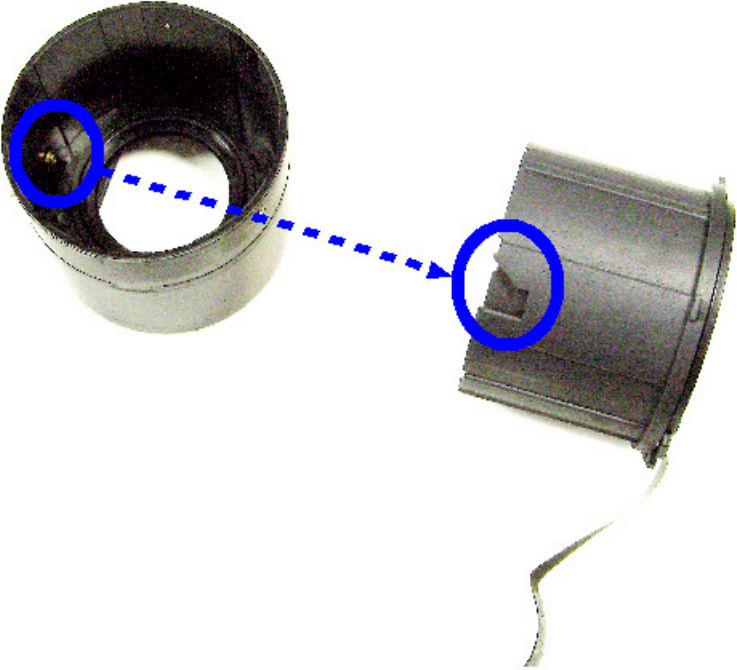

## VI. SERVICE INFORMATION

---

11. Disassemble the Shutter PCB.(Both side tape)



12. Disassemble the Guide plate.



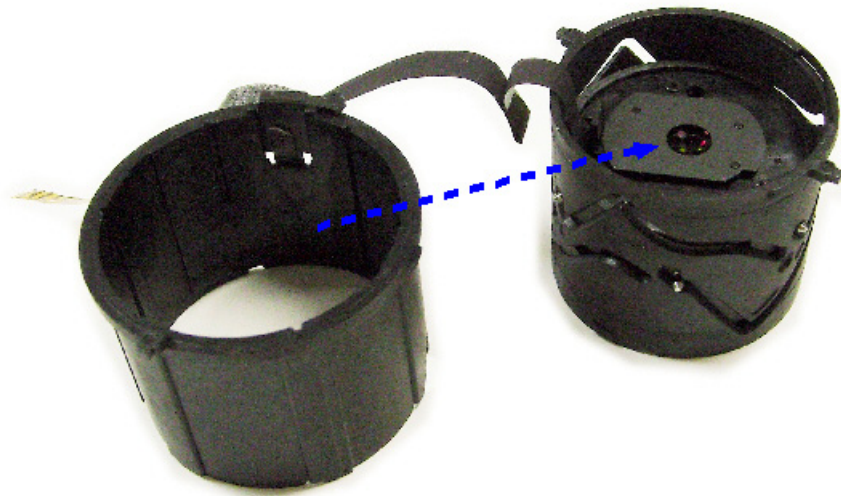

13. Be careful of 3 pin position at the Shutter Ass'y.





■ Assemble Barrel

1. Put the Spring at the GUIDE PLATE.



2. Locate the Shutter Assy attending the position.

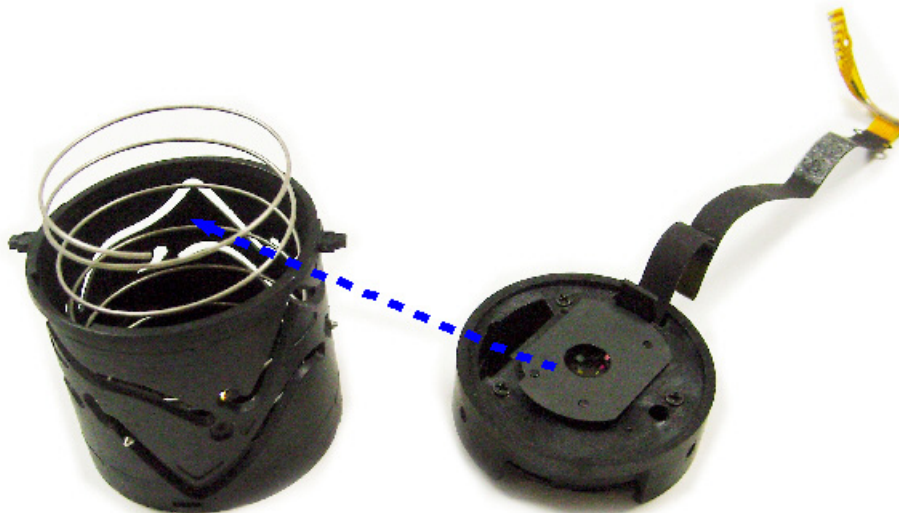

## VI. SERVICE INFORMATION

---

3. Assemble the 3 pins of Suther ass'y.



4. Assemble the Guide Plate.

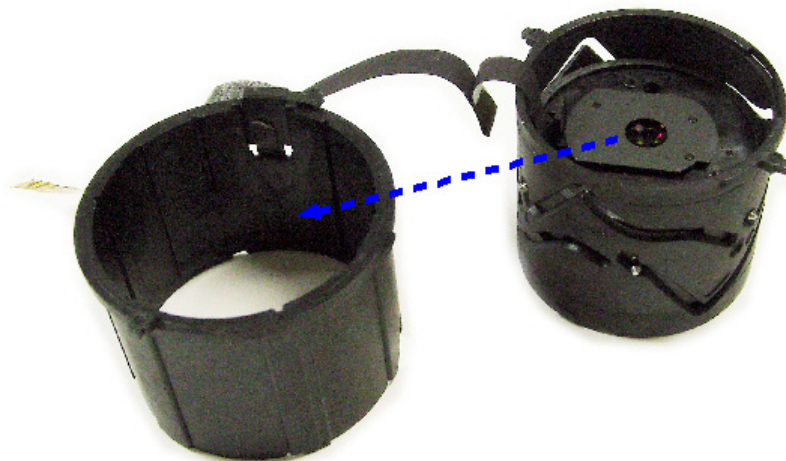





## VI. SERVICE INFORMATION

---

5. Inserte the Shutter PCB. (Both side tape)



6. Assemble the Zoom Ring Ass'y cautioning Pin position.

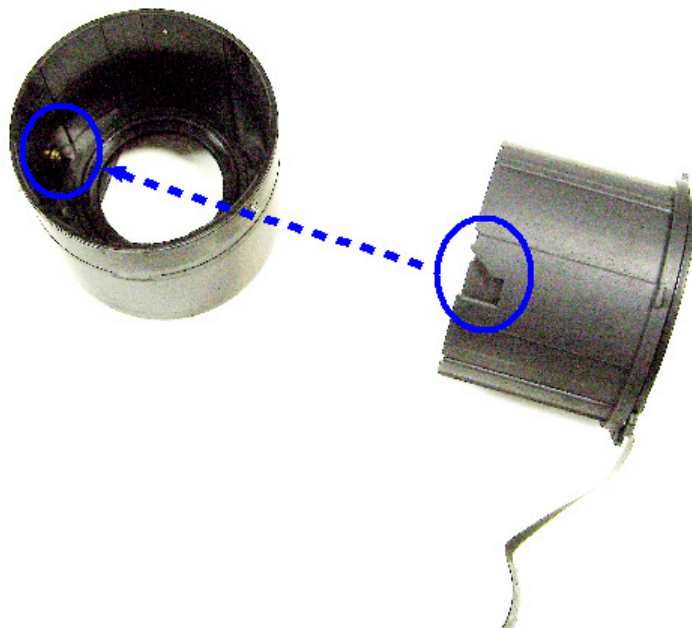



## VI. SERVICE INFORMATION

---

7. Assemble the INNER CAM BARREL ASSY.



8. Assemble the CAM BARREL ASSY.



## VI. SERVICE INFORMATION

---

9. Move to Tele position like below.



10. Assemble the Shutter PCB.





## VI. SERVICE INFORMATION

---

11. Move to the Wide position.

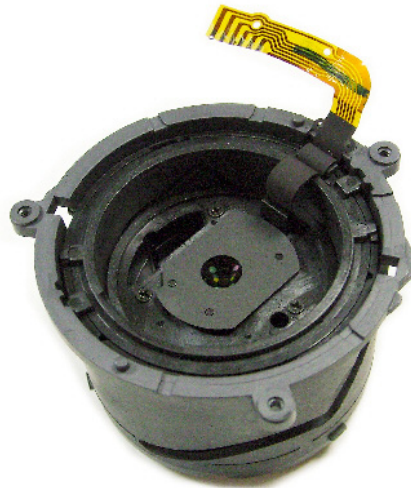



12. Assemble the OUTER GUIDE BARREL.

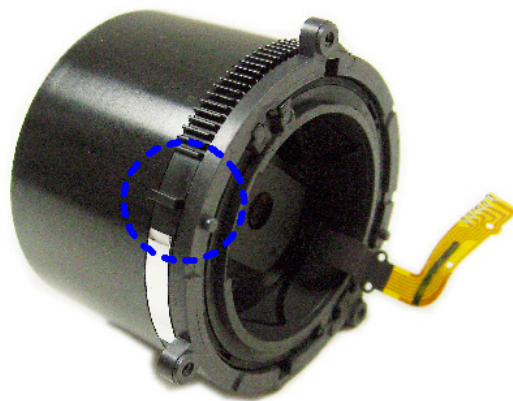
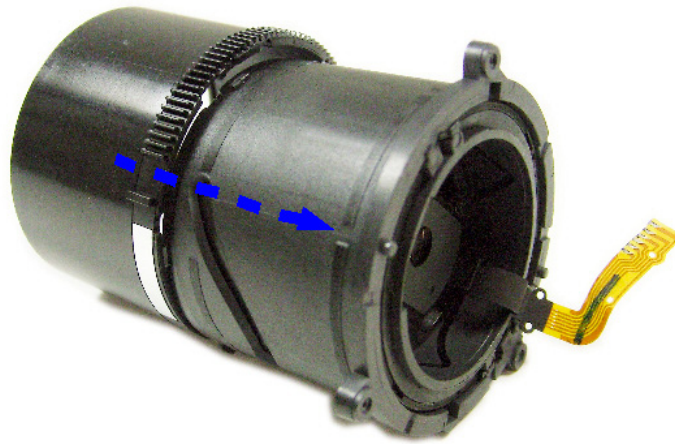
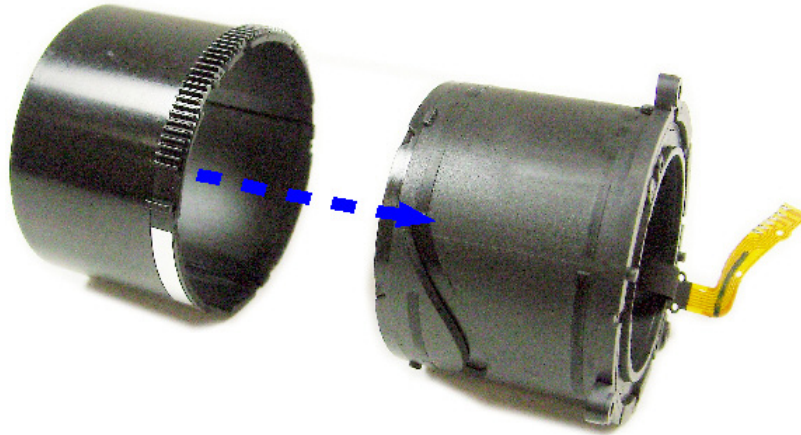

## VI. SERVICE INFORMATION

---

13. Assemble the LENS BASE ASSY.

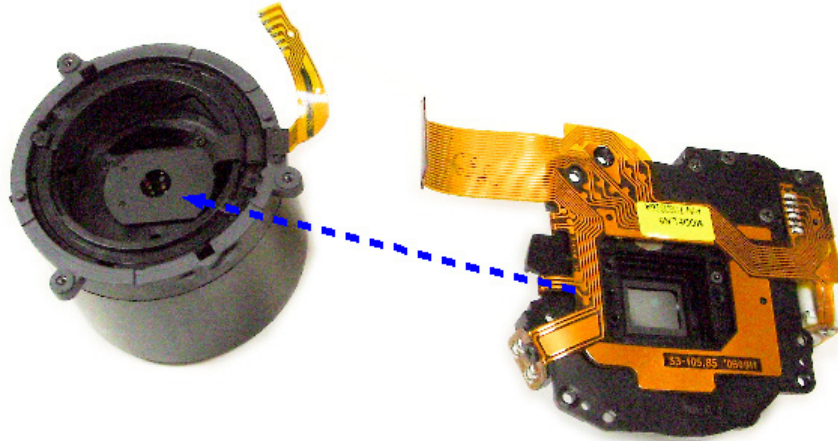

14. Assemble 3 screws

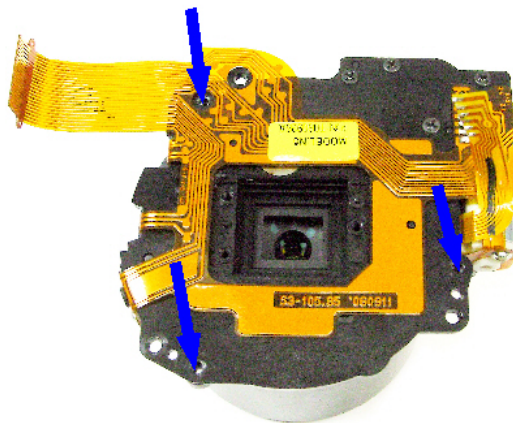

15. Solder the Shutter F PCB.

